

Lecture Notes: Introduction to the Finite Element Method

Yijun Liu

CAE Research Laboratory
Mechanical Engineering Department
University of Cincinnati
Cincinnati, OH 45221-0072, U.S.A.

E-mail: Yijun.Liu@uc.edu

Web: <http://urbana.mie.uc.edu/yliu>

This document is downloaded from the course website:

<http://urbana.mie.uc.edu/yliu/FEM-525/FEM-525.htm>

(Last Updated: May 21, 2003)

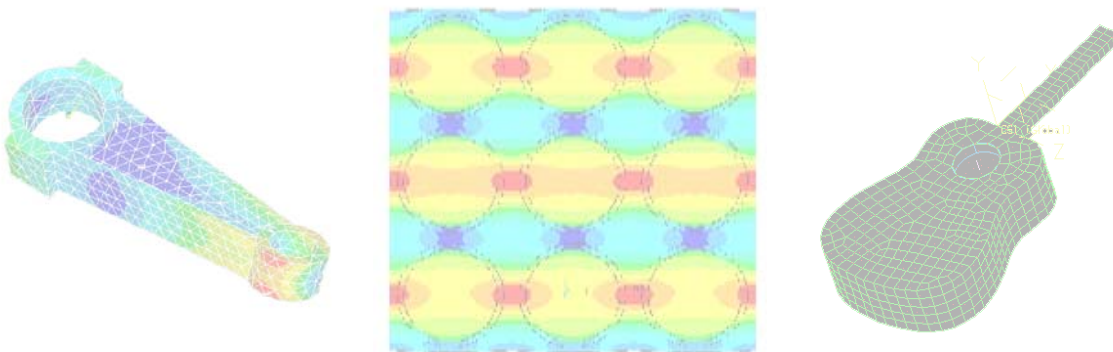

© 1997-2003 by Yijun Liu, University of Cincinnati.

Copyright Notice

© 1997-2003 by Yijun Liu, University of Cincinnati.

All rights reserved. Permissions are granted for personal and educational uses only. Any other uses of these lecture notes (such as for classroom lectures outside the University of Cincinnati, trainings elsewhere, and those of a commercial nature) are not permitted, unless such uses have been granted in writing by the author.

Table of Contents

<i>Copyright Notice</i>	<i>ii</i>
<i>Table of Contents</i>	<i>iii</i>
<i>Preface</i>	<i>v</i>
<i>Chapter 1. Introduction</i>	<i>1</i>
<i>I. Basic Concepts</i>	<i>1</i>
<i>II. Review of Matrix Algebra</i>	<i>7</i>
<i>III. Spring Element</i>	<i>14</i>
<i>Chapter 2. Bar and Beam Elements</i>	<i>25</i>
<i>I. Linear Static Analysis</i>	<i>25</i>
<i>II. Bar Element</i>	<i>26</i>
<i>III. Beam Element</i>	<i>53</i>
<i>Chapter 3. Two-Dimensional Problems</i>	<i>75</i>
<i>I. Review of the Basic Theory</i>	<i>75</i>
<i>II. Finite Elements for 2-D Problems</i>	<i>82</i>
<i>Chapter 4. Finite Element Modeling and Solution Techniques</i>	<i>105</i>
<i>I. Symmetry</i>	<i>105</i>
<i>II. Substructures (Superelements)</i>	<i>107</i>
<i>III. Equation Solving</i>	<i>109</i>
<i>IV. Nature of Finite Element Solutions</i>	<i>112</i>
<i>V. Numerical Error</i>	<i>114</i>

VI. Convergence of FE Solutions	116
VII. Adaptivity (h-, p-, and hp-Methods)	117
Chapter 5. Plate and Shell Elements	119
I. Plate Theory	119
II. Plate Elements	129
III. Shells and Shell Elements	133
Chapter 6. Solid Elements for 3-D Problems	138
I. 3-D Elasticity Theory	138
II. Finite Element Formulation	142
III. Typical 3-D Solid Elements	144
Chapter 7. Structural Vibration and Dynamics	157
I. Basic Equations	157
II. Free Vibration	163
III. Damping	167
IV. Modal Equations	168
V. Frequency Response Analysis	171
VI. Transient Response Analysis	172
Chapter 8. Thermal Analysis	177
I. Temperature Field	177
II. Thermal Stress Analysis	180
Further Reading	183

Preface

These online lecture notes (in the form of an *e-book*) are intended to serve as an introduction to the finite element method (FEM) for undergraduate students or other readers who have no previous experience with this computational method. The notes cover the basic concepts in the FEM using the simplest mechanics problems as examples, and lead to the discussions and applications of the 1-D bar and beam, 2-D plane and 3-D solid elements in the analyses of structural stresses, vibrations and dynamics. The proper usage of the FEM, as a popular numerical tool in engineering, is emphasized throughout the notes.

This online document is based on the lecture notes developed by the author since 1997 for the undergraduate course on the FEM in the mechanical engineering department at the University of Cincinnati. Since this is an *e-book*, the author suggests that the readers keep it that way and view it either online or offline on his/her computer. The contents and styles of these notes will definitely change from time to time, and therefore hard copies may become obsolete immediately after they are printed. Readers are welcome to [contact the author](#) for any suggestions on improving this *e-book* and to report any mistakes in the presentations of the subjects or typographical errors. The ultimate goal of this *e-book* on the FEM is to make it readily available for students, researchers and engineers, worldwide, to help them learn subjects in the FEM and eventually solve their own design and analysis problems using the FEM.

The author thanks his former undergraduate and graduate students for their suggestions on the earlier versions of these lecture notes and for their contributions to many of the examples used in the current version of the notes.

Yijun Liu
Cincinnati, Ohio, USA
December 2002

Chapter 1. Introduction

I. Basic Concepts

The *finite element method* (FEM), or *finite element analysis* (FEA), is based on the idea of building a complicated object with simple blocks, or, dividing a complicated object into small and manageable pieces. Application of this simple idea can be found everywhere in everyday life, as well as in engineering.

Examples:

- Lego (kids' play)
- Buildings
- Approximation of the area of a circle:

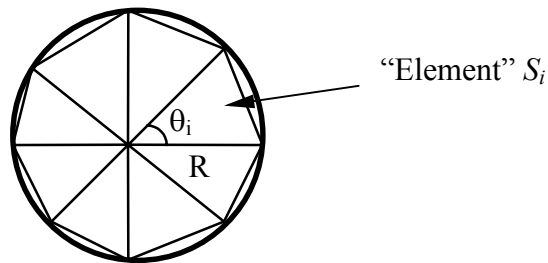

Area of one triangle: $S_i = \frac{1}{2} R^2 \sin \theta_i$

Area of the circle: $S_N = \sum_{i=1}^N S_i = \frac{1}{2} R^2 N \sin\left(\frac{2\pi}{N}\right) \rightarrow \pi R^2$ as $N \rightarrow \infty$

where N = total number of triangles (elements).

Observation: Complicated or smooth objects can be represented by geometrically simple pieces (elements).

Why Finite Element Method?

- *Design analysis*: hand calculations, experiments, and computer simulations
- FEM/FEA is the most widely applied computer simulation method in engineering
- Closely integrated with CAD/CAM applications
- ...

Applications of FEM in Engineering

- Mechanical/Aerospace/Civil/Automobile Engineering
- Structure analysis (static/dynamic, linear/nonlinear)
- Thermal/fluid flows
- Electromagnetics
- Geomechanics
- Biomechanics
- ...

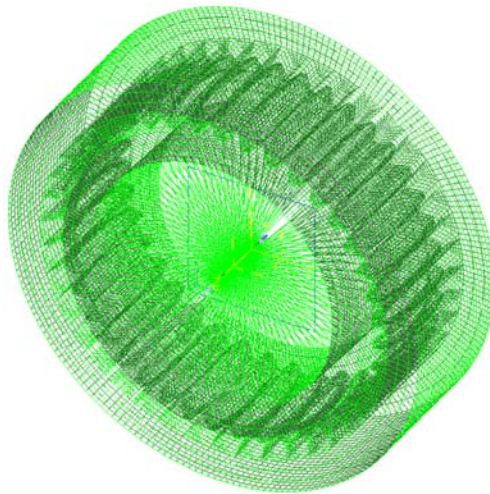

Modeling of gear coupling

Examples:

...

A Brief History of the FEM

- 1943 ----- Courant (Variational methods)
- 1956 ----- Turner, Clough, Martin and Topp (Stiffness)
- 1960 ----- Clough (“Finite Element”, plane problems)

- 1970s ----- Applications on mainframe computers
- 1980s ----- Microcomputers, pre- and postprocessors
- 1990s ----- Analysis of large structural systems

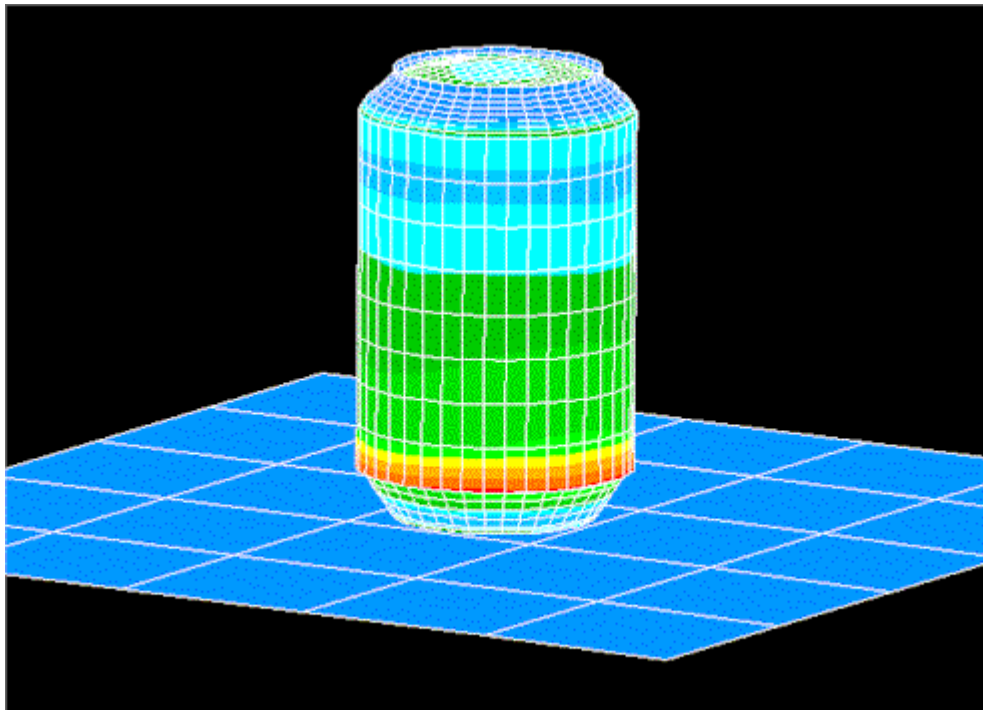

[Can Drop Test \(Click for more information and an animation\)](#)

FEM in Structural Analysis (The Procedure)

- Divide structure into pieces (elements with nodes)
- Describe the behavior of the physical quantities on each element
- Connect (assemble) the elements at the nodes to form an approximate system of equations for the whole structure
- Solve the system of equations involving unknown quantities at the nodes (e.g., displacements)
- Calculate desired quantities (e.g., strains and stresses) at selected elements

Example:

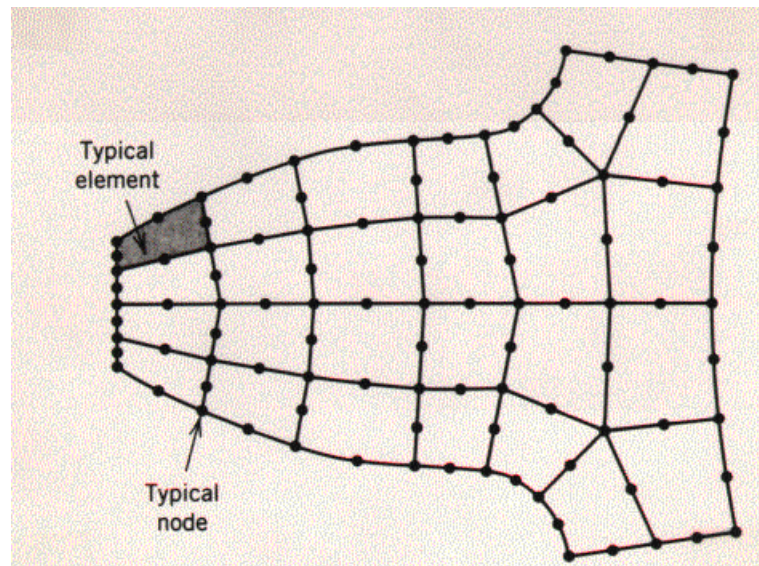

FEM model for a gear tooth (From Cook's book, p.2).

Computer Implementations

- Preprocessing (build FE model, loads and constraints)
- FEA solver (assemble and solve the system of equations)
- Postprocessing (sort and display the results)

Available Commercial FEM Software Packages

- *ANSYS* (General purpose, PC and workstations)
- *SDRC/I-DEAS* (Complete CAD/CAM/CAE package)
- *NASTRAN* (General purpose FEA on mainframes)
- *ABAQUS* (Nonlinear and dynamic analyses)
- *COSMOS* (General purpose FEA)
- *ALGOR* (PC and workstations)
- *PATRAN* (Pre/Post Processor)
- *HyperMesh* (Pre/Post Processor)
- *Dyna-3D* (Crash/impact analysis)
- ...

[A Link to CAE Software and Companies](#)

Objectives of This FEM Course

- Understand the fundamental ideas of the FEM
- Know the behavior and usage of each type of elements covered in this course
- Be able to prepare a suitable FE model for given problems
- Can interpret and evaluate the quality of the results (know the physics of the problems)
- Be aware of the limitations of the FEM (don't misuse the FEM - a numerical tool)

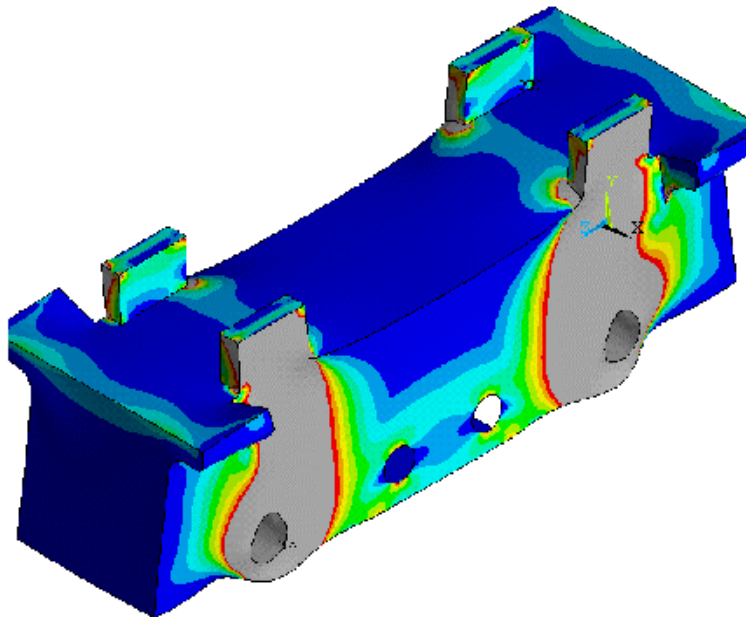

[FEA of an Unloader Trolley \(Click for more info\)](#)

By Jeff Badertscher (ME Class of 2001, UC)

See more examples in:

[**Showcase: Finite Element Analysis in Actions**](#)

II. Review of Matrix Algebra

Linear System of Algebraic Equations

$$\begin{aligned}
 a_{11}x_1 + a_{12}x_2 + \dots + a_{1n}x_n &= b_1 \\
 a_{21}x_1 + a_{22}x_2 + \dots + a_{2n}x_n &= b_2 \\
 &\dots\dots\dots \\
 a_{n1}x_1 + a_{n2}x_2 + \dots + a_{nn}x_n &= b_n
 \end{aligned} \tag{1}$$

where x_1, x_2, \dots, x_n are the unknowns.

In matrix form:

$$\mathbf{Ax} = \mathbf{b} \tag{2}$$

where

$$\mathbf{A} = [a_{ij}] = \begin{bmatrix} a_{11} & a_{12} & \dots & a_{1n} \\ a_{21} & a_{22} & \dots & a_{2n} \\ \dots & \dots & \dots & \dots \\ a_{n1} & a_{n2} & \dots & a_{nn} \end{bmatrix} \tag{3}$$

$$\mathbf{x} = \{x_i\} = \begin{Bmatrix} x_1 \\ x_2 \\ \vdots \\ x_n \end{Bmatrix} \quad \mathbf{b} = \{b_i\} = \begin{Bmatrix} b_1 \\ b_2 \\ \vdots \\ b_n \end{Bmatrix}$$

\mathbf{A} is called a $n \times n$ (square) matrix, and \mathbf{x} and \mathbf{b} are (column) vectors of dimension n .

Row and Column Vectors

$$\mathbf{v} = [v_1 \quad v_2 \quad v_3] \quad \mathbf{w} = \begin{Bmatrix} w_1 \\ w_2 \\ w_3 \end{Bmatrix}$$

Matrix Addition and Subtraction

For two matrices \mathbf{A} and \mathbf{B} , both of the *same size* ($m \times n$), the addition and subtraction are defined by

$$\mathbf{C} = \mathbf{A} + \mathbf{B} \quad \text{with} \quad c_{ij} = a_{ij} + b_{ij}$$

$$\mathbf{D} = \mathbf{A} - \mathbf{B} \quad \text{with} \quad d_{ij} = a_{ij} - b_{ij}$$

Scalar Multiplication

$$\lambda \mathbf{A} = [\lambda a_{ij}]$$

Matrix Multiplication

For two matrices \mathbf{A} (of size $l \times m$) and \mathbf{B} (of size $m \times n$), the product of \mathbf{AB} is defined by

$$\mathbf{C} = \mathbf{AB} \quad \text{with} \quad c_{ij} = \sum_{k=1}^m a_{ik} b_{kj}$$

where $i = 1, 2, \dots, l$; $j = 1, 2, \dots, n$.

Note that, in general, $\mathbf{AB} \neq \mathbf{BA}$, but $(\mathbf{AB})\mathbf{C} = \mathbf{A}(\mathbf{BC})$ (associative).

Transpose of a Matrix

If $\mathbf{A} = [a_{ij}]$, then the transpose of \mathbf{A} is

$$\mathbf{A}^T = [a_{ji}]$$

Notice that $(\mathbf{AB})^T = \mathbf{B}^T \mathbf{A}^T$.

Symmetric Matrix

A square ($n \times n$) matrix \mathbf{A} is called symmetric, if

$$\mathbf{A} = \mathbf{A}^T \quad \text{or} \quad a_{ij} = a_{ji}$$

Unit (Identity) Matrix

$$\mathbf{I} = \begin{bmatrix} 1 & 0 & \dots & 0 \\ 0 & 1 & \dots & 0 \\ \dots & \dots & \dots & \dots \\ 0 & 0 & \dots & 1 \end{bmatrix}$$

Note that $\mathbf{AI} = \mathbf{A}$, $\mathbf{Ix} = \mathbf{x}$.

Determinant of a Matrix

The determinant of *square* matrix \mathbf{A} is a scalar number denoted by $\det \mathbf{A}$ or $|\mathbf{A}|$. For 2×2 and 3×3 matrices, their determinants are given by

$$\det \begin{bmatrix} a & b \\ c & d \end{bmatrix} = ad - bc$$

and

$$\det \begin{bmatrix} a_{11} & a_{12} & a_{13} \\ a_{21} & a_{22} & a_{23} \\ a_{31} & a_{32} & a_{33} \end{bmatrix} = a_{11}a_{22}a_{33} + a_{12}a_{23}a_{31} + a_{21}a_{32}a_{13} \\ - a_{13}a_{22}a_{31} - a_{12}a_{21}a_{33} - a_{23}a_{32}a_{11}$$

Singular Matrix

A square matrix \mathbf{A} is *singular* if $\det \mathbf{A} = 0$, which indicates problems in the systems (nonunique solutions, degeneracy, etc.)

Matrix Inversion

For a square and nonsingular matrix \mathbf{A} ($\det \mathbf{A} \neq 0$), its inverse \mathbf{A}^{-1} is constructed in such a way that

$$\mathbf{A}\mathbf{A}^{-1} = \mathbf{A}^{-1}\mathbf{A} = \mathbf{I}$$

The *cofactor matrix* \mathbf{C} of matrix \mathbf{A} is defined by

$$C_{ij} = (-1)^{i+j} M_{ij}$$

where M_{ij} is the determinant of the smaller matrix obtained by eliminating the i th row and j th column of \mathbf{A} .

Thus, the inverse of \mathbf{A} can be determined by

$$\mathbf{A}^{-1} = \frac{1}{\det \mathbf{A}} \mathbf{C}^T$$

We can show that $(\mathbf{AB})^{-1} = \mathbf{B}^{-1}\mathbf{A}^{-1}$.

Examples:

$$(1) \begin{bmatrix} a & b \\ c & d \end{bmatrix}^{-1} = \frac{1}{(ad-bc)} \begin{bmatrix} d & -b \\ -c & a \end{bmatrix}$$

Checking,

$$\begin{bmatrix} a & b \\ c & d \end{bmatrix}^{-1} \begin{bmatrix} a & b \\ c & d \end{bmatrix} = \frac{1}{(ad-bc)} \begin{bmatrix} d & -b \\ -c & a \end{bmatrix} \begin{bmatrix} a & b \\ c & d \end{bmatrix} = \begin{bmatrix} 1 & 0 \\ 0 & 1 \end{bmatrix}$$

$$(2) \begin{bmatrix} 1 & -1 & 0 \\ -1 & 2 & -1 \\ 0 & -1 & 2 \end{bmatrix}^{-1} = \frac{1}{(4-2-1)} \begin{bmatrix} 3 & 2 & 1 \\ 2 & 2 & 1 \\ 1 & 1 & 1 \end{bmatrix}^T = \begin{bmatrix} 3 & 2 & 1 \\ 2 & 2 & 1 \\ 1 & 1 & 1 \end{bmatrix}$$

Checking,

$$\begin{bmatrix} 1 & -1 & 0 \\ -1 & 2 & -1 \\ 0 & -1 & 2 \end{bmatrix} \begin{bmatrix} 3 & 2 & 1 \\ 2 & 2 & 1 \\ 1 & 1 & 1 \end{bmatrix} = \begin{bmatrix} 1 & 0 & 0 \\ 0 & 1 & 0 \\ 0 & 0 & 1 \end{bmatrix}$$

If $\det \mathbf{A} = 0$ (i.e., \mathbf{A} is singular), then \mathbf{A}^{-1} does not exist!

The solution of the linear system of equations (Eq.(1)) can be expressed as (assuming the coefficient matrix \mathbf{A} is nonsingular)

$$\mathbf{x} = \mathbf{A}^{-1} \mathbf{b}$$

Thus, the main task in solving a linear system of equations is to found the inverse of the coefficient matrix.

Solution Techniques for Linear Systems of Equations

- Gauss elimination methods
- Iterative methods

Positive Definite Matrix

A square ($n \times n$) matrix \mathbf{A} is said to be *positive definite*, if for all nonzero vector \mathbf{x} of dimension n ,

$$\mathbf{x}^T \mathbf{A} \mathbf{x} > 0$$

Note that positive definite matrices are nonsingular.

Differentiation and Integration of a Matrix

Let

$$\mathbf{A}(t) = [a_{ij}(t)]$$

then the differentiation is defined by

$$\frac{d}{dt} \mathbf{A}(t) = \left[\frac{da_{ij}(t)}{dt} \right]$$

and the integration by

$$\int \mathbf{A}(t) dt = \left[\int a_{ij}(t) dt \right]$$

Types of Finite Elements

1-D (Line) Element



(Spring, truss, beam, pipe, etc.)

2-D (Plane) Element

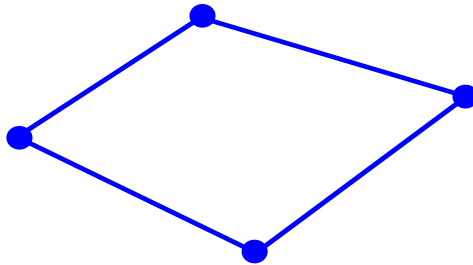

(Membrane, plate, shell, etc.)

3-D (Solid) Element

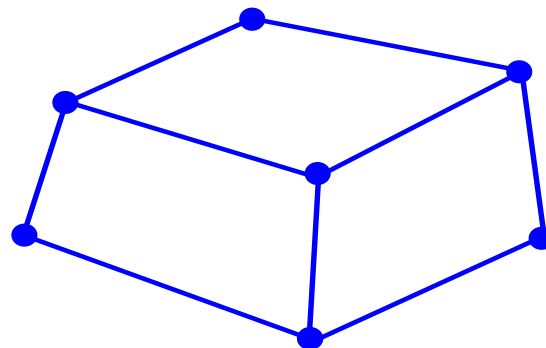

(3-D fields - temperature, displacement, stress, flow velocity)

III. Spring Element

“Everything important is simple.”

One Spring Element

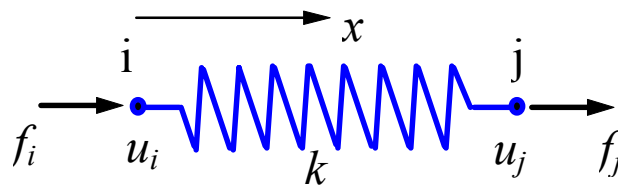

Two nodes: i, j
 Nodal displacements: u_i, u_j (in, m, mm)
 Nodal forces: f_i, f_j (lb, Newton)
 Spring constant (stiffness): k (lb/in, N/m, N/mm)

Spring force-displacement relationship:

$$F = k\Delta \quad \text{with } \Delta = u_j - u_i$$

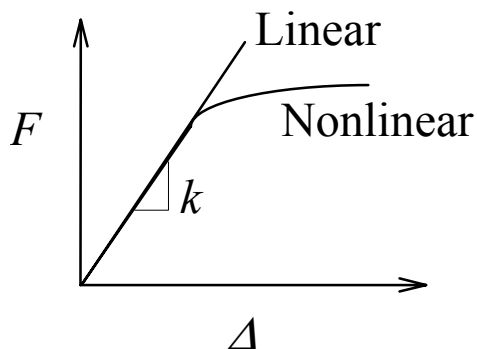

$k = F / \Delta$ (> 0) is the force needed to produce a unit stretch.

We only consider **linear problems** in this introductory course.

Consider the equilibrium of forces for the spring. At node i , we have

$$f_i = -F = -k(u_j - u_i) = ku_i - ku_j$$

and at node j ,

$$f_j = F = k(u_j - u_i) = -ku_i + ku_j$$

In matrix form,

$$\begin{bmatrix} k & -k \\ -k & k \end{bmatrix} \begin{Bmatrix} u_i \\ u_j \end{Bmatrix} = \begin{Bmatrix} f_i \\ f_j \end{Bmatrix}$$

or,

$$\mathbf{ku} = \mathbf{f}$$

where

\mathbf{k} = (element) stiffness matrix

\mathbf{u} = (element nodal) displacement vector

\mathbf{f} = (element nodal) force vector

Note that \mathbf{k} is symmetric. Is \mathbf{k} singular or nonsingular? That is, can we solve the equation? If not, why?

Spring System

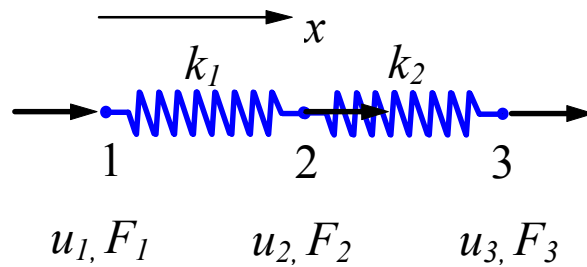

For element 1,

$$\begin{bmatrix} k_1 & -k_1 \\ -k_1 & k_1 \end{bmatrix} \begin{Bmatrix} u_1 \\ u_2 \end{Bmatrix} = \begin{Bmatrix} f_1^1 \\ f_2^1 \end{Bmatrix}$$

element 2,

$$\begin{bmatrix} k_2 & -k_2 \\ -k_2 & k_2 \end{bmatrix} \begin{Bmatrix} u_2 \\ u_3 \end{Bmatrix} = \begin{Bmatrix} f_1^2 \\ f_2^2 \end{Bmatrix}$$

where f_i^m is the (internal) force acting on *local* node i of element m ($i = 1, 2$).

Assemble the stiffness matrix for the whole system:

Consider the equilibrium of forces at node 1,

$$F_1 = f_1^1$$

at node 2,

$$F_2 = f_2^1 + f_1^2$$

and node 3,

$$F_3 = f_2^2$$

That is,

$$\begin{aligned} F_1 &= k_1 u_1 - k_1 u_2 \\ F_2 &= -k_1 u_1 + (k_1 + k_2) u_2 - k_2 u_3 \\ F_3 &= -k_2 u_2 + k_2 u_3 \end{aligned}$$

In matrix form,

$$\begin{bmatrix} k_1 & -k_1 & 0 \\ -k_1 & k_1 + k_2 & -k_2 \\ 0 & -k_2 & k_2 \end{bmatrix} \begin{Bmatrix} u_1 \\ u_2 \\ u_3 \end{Bmatrix} = \begin{Bmatrix} F_1 \\ F_2 \\ F_3 \end{Bmatrix}$$

or

$$\mathbf{K}\mathbf{U} = \mathbf{F}$$

\mathbf{K} is the stiffness matrix (structure matrix) for the spring system.

An alternative way of assembling the whole stiffness matrix:

“Enlarging” the stiffness matrices for elements 1 and 2, we have

$$\begin{bmatrix} k_1 & -k_1 & 0 \\ -k_1 & k_1 & 0 \\ 0 & 0 & 0 \end{bmatrix} \begin{Bmatrix} u_1 \\ u_2 \\ u_3 \end{Bmatrix} = \begin{Bmatrix} f_1^1 \\ f_2^1 \\ 0 \end{Bmatrix}$$

$$\begin{bmatrix} 0 & 0 & 0 \\ 0 & k_2 & -k_2 \\ 0 & -k_2 & k_2 \end{bmatrix} \begin{Bmatrix} u_1 \\ u_2 \\ u_3 \end{Bmatrix} = \begin{Bmatrix} 0 \\ f_1^2 \\ f_2^2 \end{Bmatrix}$$

Adding the two matrix equations (*superposition*), we have

$$\begin{bmatrix} k_1 & -k_1 & 0 \\ -k_1 & k_1 + k_2 & -k_2 \\ 0 & -k_2 & k_2 \end{bmatrix} \begin{Bmatrix} u_1 \\ u_2 \\ u_3 \end{Bmatrix} = \begin{Bmatrix} f_1^1 \\ f_2^1 + f_1^2 \\ f_2^2 \end{Bmatrix}$$

This is the same equation we derived by using the force equilibrium concept.

Boundary and load conditions:

Assuming, $u_1 = 0$ and $F_2 = F_3 = P$

we have

$$\begin{bmatrix} k_1 & -k_1 & 0 \\ -k_1 & k_1 + k_2 & -k_2 \\ 0 & -k_2 & k_2 \end{bmatrix} \begin{Bmatrix} 0 \\ u_2 \\ u_3 \end{Bmatrix} = \begin{Bmatrix} F_1 \\ P \\ P \end{Bmatrix}$$

which reduces to

$$\begin{bmatrix} k_1 + k_2 & -k_2 \\ -k_2 & k_2 \end{bmatrix} \begin{Bmatrix} u_2 \\ u_3 \end{Bmatrix} = \begin{Bmatrix} P \\ P \end{Bmatrix}$$

and

$$F_1 = -k_1 u_2$$

Unknowns are

$$\mathbf{U} = \begin{Bmatrix} u_2 \\ u_3 \end{Bmatrix} \quad \text{and the reaction force } F_1 \text{ (if desired).}$$

Solving the equations, we obtain the displacements

$$\begin{Bmatrix} u_2 \\ u_3 \end{Bmatrix} = \begin{Bmatrix} 2P / k_1 \\ 2P / k_1 + P / k_2 \end{Bmatrix}$$

and the reaction force

$$F_1 = -2P$$

Checking the Results

- Deformed shape of the structure
- Balance of the external forces
- Order of magnitudes of the numbers

Notes About the Spring Elements

- Suitable for stiffness analysis
- Not suitable for stress analysis of the spring itself
- Can have spring elements with stiffness in the lateral direction, spring elements for torsion, etc.

Example 1.1

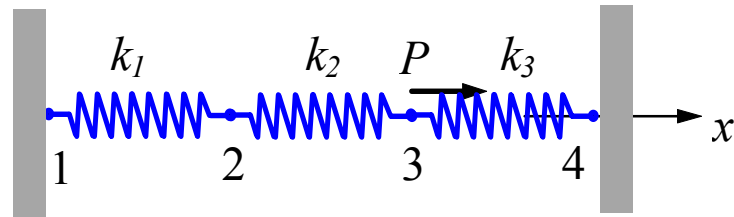

Given: For the spring system shown above,

$$k_1 = 100 \text{ N/mm}, \quad k_2 = 200 \text{ N/mm}, \quad k_3 = 100 \text{ N/mm}$$

$$P = 500 \text{ N}, \quad u_1 = u_4 = 0$$

- Find:*
- the global stiffness matrix
 - displacements of nodes 2 and 3
 - the reaction forces at nodes 1 and 4
 - the force in the spring 2

Solution:

(a) The element stiffness matrices are

$$\mathbf{k}_1 = \begin{bmatrix} 100 & -100 \\ -100 & 100 \end{bmatrix} \quad (\text{N/mm}) \quad (1)$$

$$\mathbf{k}_2 = \begin{bmatrix} 200 & -200 \\ -200 & 200 \end{bmatrix} \quad (\text{N/mm}) \quad (2)$$

$$\mathbf{k}_3 = \begin{bmatrix} 100 & -100 \\ -100 & 100 \end{bmatrix} \quad (\text{N/mm}) \quad (3)$$

Applying the superposition concept, we obtain the global stiffness matrix for the spring system as

$$\mathbf{K} = \begin{bmatrix} & u_1 & u_2 & u_3 & u_4 \\ \begin{bmatrix} 100 & -100 \\ -100 & 100 \end{bmatrix} & & & & \\ & & \begin{bmatrix} 200 & -200 \\ -200 & 200 \end{bmatrix} & & \\ & & & \begin{bmatrix} 100 & -100 \\ -100 & 100 \end{bmatrix} & \\ & & & & \end{bmatrix}$$

or

$$\mathbf{K} = \begin{bmatrix} 100 & -100 & 0 & 0 \\ -100 & 300 & -200 & 0 \\ 0 & -200 & 300 & -100 \\ 0 & 0 & -100 & 100 \end{bmatrix}$$

which is *symmetric* and *banded*.

Equilibrium (FE) equation for the whole system is

$$\begin{bmatrix} 100 & -100 & 0 & 0 \\ -100 & 300 & -200 & 0 \\ 0 & -200 & 300 & -100 \\ 0 & 0 & -100 & 100 \end{bmatrix} \begin{Bmatrix} u_1 \\ u_2 \\ u_3 \\ u_4 \end{Bmatrix} = \begin{Bmatrix} F_1 \\ 0 \\ P \\ F_4 \end{Bmatrix} \quad (4)$$

(b) Applying the BC ($u_1 = u_4 = 0$) in Eq(4), or deleting the 1st and 4th rows and columns, we have

$$\begin{bmatrix} 300 & -200 \\ -200 & 300 \end{bmatrix} \begin{Bmatrix} u_2 \\ u_3 \end{Bmatrix} = \begin{Bmatrix} 0 \\ P \end{Bmatrix} \quad (5)$$

Solving Eq.(5), we obtain

$$\begin{Bmatrix} u_2 \\ u_3 \end{Bmatrix} = \begin{Bmatrix} P/250 \\ 3P/500 \end{Bmatrix} = \begin{Bmatrix} 2 \\ 3 \end{Bmatrix} \text{ (mm)} \quad (6)$$

(c) From the 1st and 4th equations in (4), we get the reaction forces

$$F_1 = -100u_2 = -200 \text{ (N)}$$

$$F_4 = -100u_3 = -300 \text{ (N)}$$

(d) The FE equation for spring (element) 2 is

$$\begin{bmatrix} 200 & -200 \\ -200 & 200 \end{bmatrix} \begin{Bmatrix} u_i \\ u_j \end{Bmatrix} = \begin{Bmatrix} f_i \\ f_j \end{Bmatrix}$$

Here $i = 2, j = 3$ for element 2. Thus we can calculate the spring force as

$$\begin{aligned} F = f_j = -f_i &= [-200 \quad 200] \begin{Bmatrix} u_2 \\ u_3 \end{Bmatrix} \\ &= [-200 \quad 200] \begin{Bmatrix} 2 \\ 3 \end{Bmatrix} \\ &= 200 \text{ (N)} \end{aligned}$$

Check the results!

Example 1.2

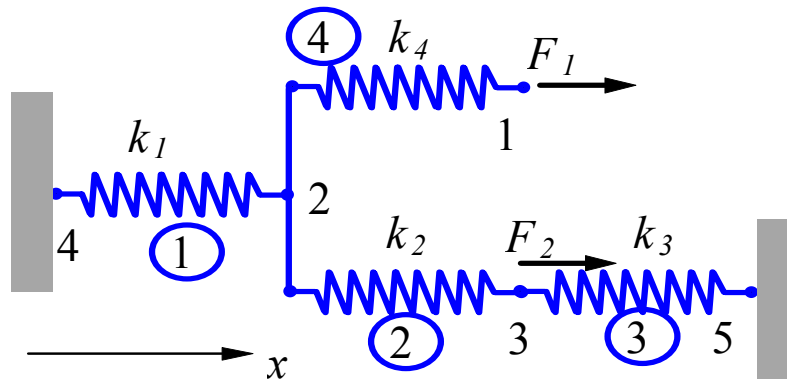

Problem: For the spring system with arbitrarily numbered nodes and elements, as shown above, find the global stiffness matrix.

Solution:

First we construct the following

Element Connectivity Table

<i>Element</i>	<i>Node i (1)</i>	<i>Node j (2)</i>
1	4	2
2	2	3
3	3	5
4	2	1

which specifies the *global* node numbers corresponding to the *local* node numbers for each element.

Then we can write the element stiffness matrices as follows

$$\mathbf{k}_1 = \begin{array}{c} u_4 \quad u_2 \\ \left[\begin{array}{cc} k_1 & -k_1 \\ -k_1 & k_1 \end{array} \right] \end{array} \quad \mathbf{k}_2 = \begin{array}{c} u_2 \quad u_3 \\ \left[\begin{array}{cc} k_2 & -k_2 \\ -k_2 & k_2 \end{array} \right] \end{array}$$

$$\mathbf{k}_3 = \begin{array}{c} u_3 \quad u_5 \\ \left[\begin{array}{cc} k_3 & -k_3 \\ -k_3 & k_3 \end{array} \right] \end{array} \quad \mathbf{k}_4 = \begin{array}{c} u_2 \quad u_1 \\ \left[\begin{array}{cc} k_4 & -k_4 \\ -k_4 & k_4 \end{array} \right] \end{array}$$

Finally, applying the superposition method, we obtain the global stiffness matrix as follows

$$\mathbf{K} = \begin{array}{c} u_1 \quad u_2 \quad u_3 \quad u_4 \quad u_5 \\ \left[\begin{array}{cc|cc|c} k_4 & -k_4 & 0 & 0 & 0 \\ -k_4 & k_1 + k_2 + k_4 & -k_2 & -k_1 & 0 \\ 0 & -k_2 & k_2 + k_3 & 0 & -k_3 \\ 0 & -k_1 & 0 & k_1 & 0 \\ 0 & 0 & -k_3 & 0 & k_3 \end{array} \right] \end{array}$$

The matrix is *symmetric*, *banded*, but *singular*.

Chapter 2. Bar and Beam Elements

I. Linear Static Analysis

Most structural analysis problems can be treated as *linear static* problems, based on the following assumptions

1. *Small deformations* (loading pattern is not changed due to the deformed shape)
2. *Elastic materials* (no plasticity or failures)
3. *Static loads* (the load is applied to the structure in a slow or steady fashion)

Linear analysis can provide most of the information about the behavior of a structure, and can be a good approximation for many analyses. It is also the bases of nonlinear analysis in most of the cases.

II. Bar Element

Consider a uniform prismatic bar:

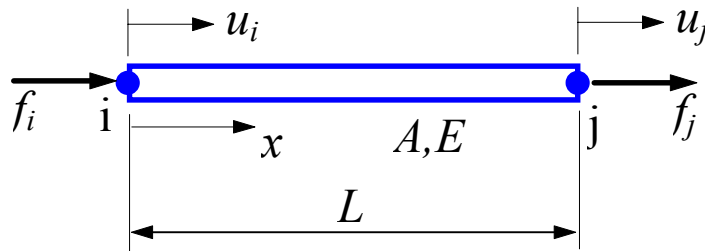

L	length
A	cross-sectional area
E	elastic modulus
$u = u(x)$	displacement
$\varepsilon = \varepsilon(x)$	strain
$\sigma = \sigma(x)$	stress

Strain-displacement relation:

$$\varepsilon = \frac{du}{dx} \quad (1)$$

Stress-strain relation:

$$\sigma = E\varepsilon \quad (2)$$

Stiffness Matrix --- Direct Method

Assuming that the displacement u is *varying linearly* along the axis of the bar, i.e.,

$$u(x) = \left(1 - \frac{x}{L}\right)u_i + \frac{x}{L}u_j \quad (3)$$

we have

$$\varepsilon = \frac{u_j - u_i}{L} = \frac{\Delta}{L} \quad (\Delta = \text{elongation}) \quad (4)$$

$$\sigma = E\varepsilon = \frac{E\Delta}{L} \quad (5)$$

We also have

$$\sigma = \frac{F}{A} \quad (F = \text{force in bar}) \quad (6)$$

Thus, (5) and (6) lead to

$$F = \frac{EA}{L}\Delta = k\Delta \quad (7)$$

where $k = \frac{EA}{L}$ is the stiffness of the bar.

The bar is acting like a spring in this case and we conclude that element stiffness matrix is

$$\mathbf{k} = \begin{bmatrix} k & -k \\ -k & k \end{bmatrix} = \begin{bmatrix} \frac{EA}{L} & -\frac{EA}{L} \\ -\frac{EA}{L} & \frac{EA}{L} \end{bmatrix}$$

or

$$\mathbf{k} = \frac{EA}{L} \begin{bmatrix} 1 & -1 \\ -1 & 1 \end{bmatrix} \quad (8)$$

This can be verified by considering the equilibrium of the forces at the two nodes.

Element equilibrium equation is

$$\frac{EA}{L} \begin{bmatrix} 1 & -1 \\ -1 & 1 \end{bmatrix} \begin{Bmatrix} u_i \\ u_j \end{Bmatrix} = \begin{Bmatrix} f_i \\ f_j \end{Bmatrix} \quad (9)$$

Degree of Freedom (dof)

Number of components of the displacement vector at a node.

For 1-D bar element: one dof at each node.

Physical Meaning of the Coefficients in \mathbf{k}

The j th column of \mathbf{k} (here $j = 1$ or 2) represents the forces applied to the bar to maintain a deformed shape with unit displacement at node j and zero displacement at the other node.

Stiffness Matrix --- A Formal Approach

We derive the same stiffness matrix for the bar using a formal approach which can be applied to many other more complicated situations.

Define two *linear shape functions* as follows

$$N_i(\xi) = 1 - \xi, \quad N_j(\xi) = \xi \quad (10)$$

where

$$\xi = \frac{x}{L}, \quad 0 \leq \xi \leq 1 \quad (11)$$

From (3) we can write the displacement as

$$u(x) = u(\xi) = N_i(\xi)u_i + N_j(\xi)u_j$$

or

$$u = \begin{bmatrix} N_i & N_j \end{bmatrix} \begin{Bmatrix} u_i \\ u_j \end{Bmatrix} = \mathbf{N}\mathbf{u} \quad (12)$$

Strain is given by (1) and (12) as

$$\varepsilon = \frac{du}{dx} = \left[\frac{d}{dx} \mathbf{N} \right] \mathbf{u} = \mathbf{B}\mathbf{u} \quad (13)$$

where \mathbf{B} is the element *strain-displacement matrix*, which is

$$\mathbf{B} = \frac{d}{dx} \begin{bmatrix} N_i(\xi) & N_j(\xi) \end{bmatrix} = \frac{d}{d\xi} \begin{bmatrix} N_i(\xi) & N_j(\xi) \end{bmatrix} \cdot \frac{d\xi}{dx}$$

$$\text{i.e.,} \quad \mathbf{B} = \begin{bmatrix} -1/L & 1/L \end{bmatrix} \quad (14)$$

Stress can be written as

$$\boldsymbol{\sigma} = E\boldsymbol{\varepsilon} = E\mathbf{B}\mathbf{u} \quad (15)$$

Consider the *strain energy* stored in the bar

$$\begin{aligned} U &= \frac{1}{2} \int_V \boldsymbol{\sigma}^T \boldsymbol{\varepsilon} dV = \frac{1}{2} \int_V (\mathbf{u}^T \mathbf{B}^T E \mathbf{B} \mathbf{u}) dV \\ &= \frac{1}{2} \mathbf{u}^T \left[\int_V (\mathbf{B}^T E \mathbf{B}) dV \right] \mathbf{u} \end{aligned} \quad (16)$$

where (13) and (15) have been used.

The *work* done by the two nodal forces is

$$W = \frac{1}{2} f_i u_i + \frac{1}{2} f_j u_j = \frac{1}{2} \mathbf{u}^T \mathbf{f} \quad (17)$$

For conservative system, we state that

$$U = W \quad (18)$$

which gives

$$\frac{1}{2} \mathbf{u}^T \left[\int_V (\mathbf{B}^T E \mathbf{B}) dV \right] \mathbf{u} = \frac{1}{2} \mathbf{u}^T \mathbf{f}$$

We can conclude that

$$\left[\int_V (\mathbf{B}^T E \mathbf{B}) dV \right] \mathbf{u} = \mathbf{f}$$

or

$$\mathbf{k}\mathbf{u} = \mathbf{f} \quad (19)$$

where

$$\mathbf{k} = \int_V (\mathbf{B}^T E \mathbf{B}) dV \quad (20)$$

is the *element stiffness matrix*.

Expression (20) is a general result which can be used for the construction of other types of elements. This expression can also be derived using other more rigorous approaches, such as the *Principle of Minimum Potential Energy*, or the *Galerkin's Method*.

Now, we evaluate (20) for the bar element by using (14)

$$\mathbf{k} = \int_0^L \begin{Bmatrix} -1/L \\ 1/L \end{Bmatrix} E [-1/L \quad 1/L] A dx = \frac{EA}{L} \begin{bmatrix} 1 & -1 \\ -1 & 1 \end{bmatrix}$$

which is the same as we derived using the direct method.

Note that from (16) and (20), the strain energy in the element can be written as

$$U = \frac{1}{2} \mathbf{u}^T \mathbf{k} \mathbf{u} \quad (21)$$

Example 2.1

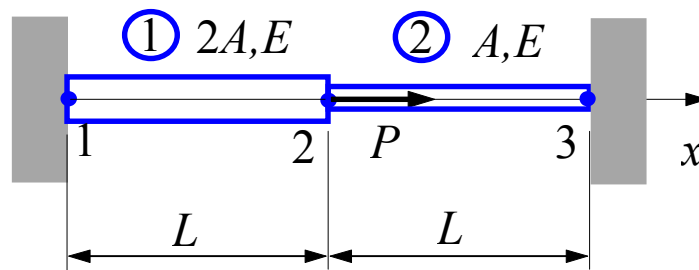

Problem: Find the stresses in the two bar assembly which is loaded with force P , and constrained at the two ends, as shown in the figure.

Solution: Use two 1-D bar elements.

Element 1,

$$\mathbf{k}_1 = \frac{2EA}{L} \begin{bmatrix} u_1 & u_2 \\ 1 & -1 \\ -1 & 1 \end{bmatrix}$$

Element 2,

$$\mathbf{k}_2 = \frac{EA}{L} \begin{bmatrix} u_2 & u_3 \\ 1 & -1 \\ -1 & 1 \end{bmatrix}$$

Imagine a frictionless pin at node 2, which connects the two elements. We can assemble the global FE equation as follows,

$$\frac{EA}{L} \begin{bmatrix} 2 & -2 & 0 \\ -2 & 3 & -1 \\ 0 & -1 & 1 \end{bmatrix} \begin{Bmatrix} u_1 \\ u_2 \\ u_3 \end{Bmatrix} = \begin{Bmatrix} F_1 \\ F_2 \\ F_3 \end{Bmatrix}$$

Load and boundary conditions (BC) are,

$$u_1 = u_3 = 0, \quad F_2 = P$$

FE equation becomes,

$$\frac{EA}{L} \begin{bmatrix} 2 & -2 & 0 \\ -2 & 3 & -1 \\ 0 & -1 & 1 \end{bmatrix} \begin{Bmatrix} 0 \\ u_2 \\ 0 \end{Bmatrix} = \begin{Bmatrix} F_1 \\ P \\ F_3 \end{Bmatrix}$$

Deleting the 1st row and column, and the 3rd row and column, we obtain,

$$\frac{EA}{L} [3] \{u_2\} = \{P\}$$

Thus,

$$u_2 = \frac{PL}{3EA}$$

and

$$\begin{Bmatrix} u_1 \\ u_2 \\ u_3 \end{Bmatrix} = \frac{PL}{3EA} \begin{Bmatrix} 0 \\ 1 \\ 0 \end{Bmatrix}$$

Stress in element 1 is

$$\begin{aligned}\sigma_1 &= E\varepsilon_1 = E\mathbf{B}_1\mathbf{u}_1 = E\begin{bmatrix} -1/L & 1/L \end{bmatrix} \begin{Bmatrix} u_1 \\ u_2 \end{Bmatrix} \\ &= E \frac{u_2 - u_1}{L} = \frac{E}{L} \left(\frac{PL}{3EA} - 0 \right) = \frac{P}{3A}\end{aligned}$$

Similarly, stress in element 2 is

$$\begin{aligned}\sigma_2 &= E\varepsilon_2 = E\mathbf{B}_2\mathbf{u}_2 = E\begin{bmatrix} -1/L & 1/L \end{bmatrix} \begin{Bmatrix} u_2 \\ u_3 \end{Bmatrix} \\ &= E \frac{u_3 - u_2}{L} = \frac{E}{L} \left(0 - \frac{PL}{3EA} \right) = -\frac{P}{3A}\end{aligned}$$

which indicates that bar 2 is in compression.

Check the results!

Notes:

- In this case, the calculated stresses in elements 1 and 2 are exact within the linear theory for 1-D bar structures. It will not help if we further divide element 1 or 2 into smaller finite elements.
- For tapered bars, averaged values of the cross-sectional areas should be used for the elements.
- We need to find the displacements first in order to find the stresses, since we are using the *displacement based FEM*.

Example 2.2

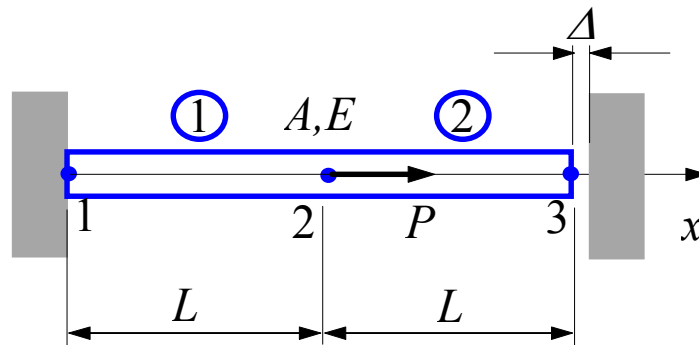

Problem: Determine the support reaction forces at the two ends of the bar shown above, given the following,

$$P = 6.0 \times 10^4 \text{ N}, \quad E = 2.0 \times 10^4 \text{ N / mm}^2, \\ A = 250 \text{ mm}^2, \quad L = 150 \text{ mm}, \quad \Delta = 1.2 \text{ mm}$$

Solution:

We first check to see if or not the contact of the bar with the wall on the right will occur. To do this, we imagine the wall on the right is removed and calculate the displacement at the right end,

$$\Delta_0 = \frac{PL}{EA} = \frac{(6.0 \times 10^4)(150)}{(2.0 \times 10^4)(250)} = 1.8 \text{ mm} > \Delta = 1.2 \text{ mm}$$

Thus, contact occurs.

The global FE equation is found to be,

$$\frac{EA}{L} \begin{bmatrix} 1 & -1 & 0 \\ -1 & 2 & -1 \\ 0 & -1 & 1 \end{bmatrix} \begin{Bmatrix} u_1 \\ u_2 \\ u_3 \end{Bmatrix} = \begin{Bmatrix} F_1 \\ F_2 \\ F_3 \end{Bmatrix}$$

The load and boundary conditions are,

$$F_2 = P = 6.0 \times 10^4 \text{ N}$$

$$u_1 = 0, \quad u_3 = \Delta = 1.2 \text{ mm}$$

FE equation becomes,

$$\frac{EA}{L} \begin{bmatrix} 1 & -1 & 0 \\ -1 & 2 & -1 \\ 0 & -1 & 1 \end{bmatrix} \begin{Bmatrix} 0 \\ u_2 \\ \Delta \end{Bmatrix} = \begin{Bmatrix} F_1 \\ P \\ F_3 \end{Bmatrix}$$

The 2nd equation gives,

$$\frac{EA}{L} [2 \quad -1] \begin{Bmatrix} u_2 \\ \Delta \end{Bmatrix} = \{P\}$$

that is,

$$\frac{EA}{L} [2] \{u_2\} = \left\{ P + \frac{EA}{L} \Delta \right\}$$

Solving this, we obtain

$$u_2 = \frac{1}{2} \left(\frac{PL}{EA} + \Delta \right) = 1.5 \text{ mm}$$

and

$$\begin{Bmatrix} u_1 \\ u_2 \\ u_3 \end{Bmatrix} = \begin{Bmatrix} 0 \\ 1.5 \\ 1.2 \end{Bmatrix} \text{ (mm)}$$

To calculate the support reaction forces, we apply the 1st and 3rd equations in the global FE equation.

The 1st equation gives,

$$F_1 = \frac{EA}{L} \begin{bmatrix} 1 & -1 & 0 \end{bmatrix} \begin{Bmatrix} u_1 \\ u_2 \\ u_3 \end{Bmatrix} = \frac{EA}{L} (-u_2) = -5.0 \times 10^4 \text{ N}$$

and the 3rd equation gives,

$$\begin{aligned} F_3 &= \frac{EA}{L} \begin{bmatrix} 0 & -1 & 1 \end{bmatrix} \begin{Bmatrix} u_1 \\ u_2 \\ u_3 \end{Bmatrix} = \frac{EA}{L} (-u_2 + u_3) \\ &= -1.0 \times 10^4 \text{ N} \end{aligned}$$

Check the results.!

Distributed Load

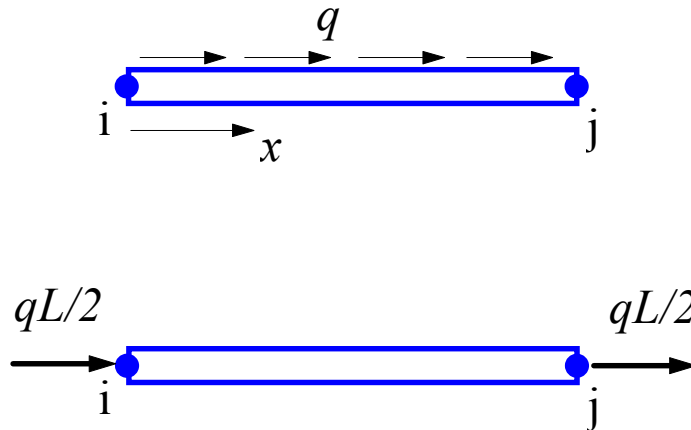

Uniformly distributed axial load q (N/mm, N/m, lb/in) can be converted to two equivalent nodal forces of magnitude $qL/2$. We verify this by considering the work done by the load q ,

$$\begin{aligned}
 W_q &= \int_0^L \frac{1}{2} u q dx = \frac{1}{2} \int_0^1 u(\xi) q (L d\xi) = \frac{qL}{2} \int_0^1 u(\xi) d\xi \\
 &= \frac{qL}{2} \int_0^1 [N_i(\xi) \quad N_j(\xi)] \begin{Bmatrix} u_i \\ u_j \end{Bmatrix} d\xi \\
 &= \frac{qL}{2} \int_0^1 [1-\xi \quad \xi] d\xi \begin{Bmatrix} u_i \\ u_j \end{Bmatrix} \\
 &= \frac{1}{2} \begin{bmatrix} qL & qL \\ 2 & 2 \end{bmatrix} \begin{Bmatrix} u_i \\ u_j \end{Bmatrix} \\
 &= \frac{1}{2} \begin{bmatrix} u_i & u_j \end{bmatrix} \begin{Bmatrix} qL/2 \\ qL/2 \end{Bmatrix}
 \end{aligned}$$

that is,

$$W_q = \frac{1}{2} \mathbf{u}^T \mathbf{f}_q \quad \text{with } \mathbf{f}_q = \begin{Bmatrix} qL/2 \\ qL/2 \end{Bmatrix} \quad (22)$$

Thus, from the $U=W$ concept for the element, we have

$$\frac{1}{2} \mathbf{u}^T \mathbf{k} \mathbf{u} = \frac{1}{2} \mathbf{u}^T \mathbf{f} + \frac{1}{2} \mathbf{u}^T \mathbf{f}_q \quad (23)$$

which yields

$$\mathbf{k} \mathbf{u} = \mathbf{f} + \mathbf{f}_q \quad (24)$$

The new nodal force vector is

$$\mathbf{f} + \mathbf{f}_q = \begin{Bmatrix} f_i + qL/2 \\ f_j + qL/2 \end{Bmatrix} \quad (25)$$

In an assembly of bars,

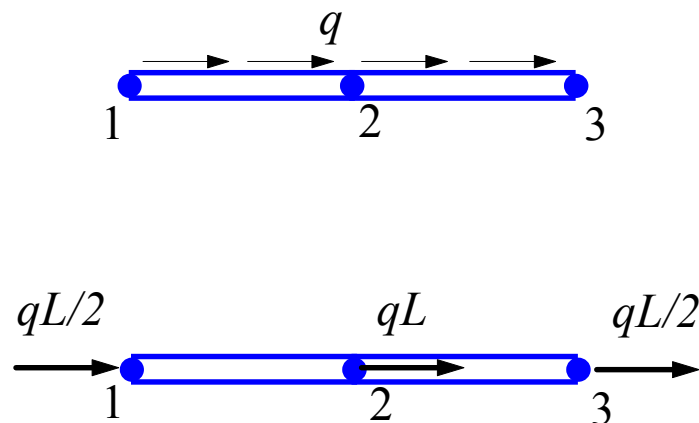

Bar Elements in 2-D and 3-D Space

2-D Case

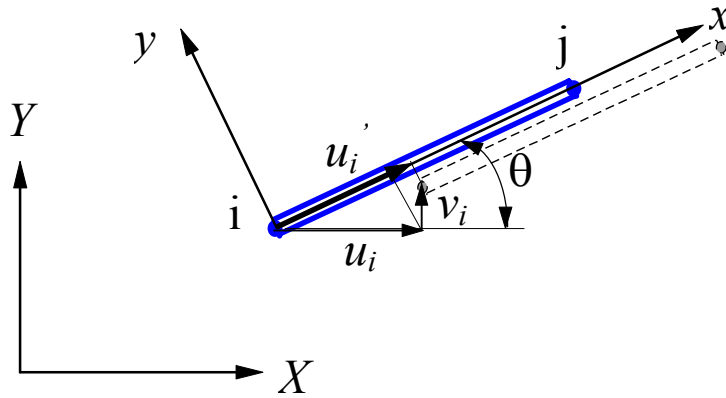

<i>Local</i>	<i>Global</i>
x, y	X, Y
u_i', v_i'	u_i, v_i
1 dof at a node	2 dof's at a node

Note: Lateral displacement v_i' does not contribute to the stretch of the bar, within the linear theory.

Transformation

$$u_i' = u_i \cos \theta + v_i \sin \theta = [l \quad m] \begin{Bmatrix} u_i \\ v_i \end{Bmatrix}$$

$$v_i' = -u_i \sin \theta + v_i \cos \theta = [-m \quad l] \begin{Bmatrix} u_i \\ v_i \end{Bmatrix}$$

where $l = \cos \theta$, $m = \sin \theta$.

In matrix form,

$$\begin{Bmatrix} u'_i \\ v'_i \end{Bmatrix} = \begin{bmatrix} l & m \\ -m & l \end{bmatrix} \begin{Bmatrix} u_i \\ v_i \end{Bmatrix} \quad (26)$$

or,

$$\mathbf{u}'_i = \tilde{\mathbf{T}} \mathbf{u}_i$$

where the *transformation matrix*

$$\tilde{\mathbf{T}} = \begin{bmatrix} l & m \\ -m & l \end{bmatrix} \quad (27)$$

is *orthogonal*, that is, $\tilde{\mathbf{T}}^{-1} = \tilde{\mathbf{T}}^T$.

For the two nodes of the bar element, we have

$$\begin{Bmatrix} u'_i \\ v'_i \\ u'_j \\ v'_j \end{Bmatrix} = \begin{bmatrix} l & m & 0 & 0 \\ -m & l & 0 & 0 \\ 0 & 0 & l & m \\ 0 & 0 & -m & l \end{bmatrix} \begin{Bmatrix} u_i \\ v_i \\ u_j \\ v_j \end{Bmatrix} \quad (28)$$

or,

$$\mathbf{u}' = \mathbf{T} \mathbf{u} \quad \text{with } \mathbf{T} = \begin{bmatrix} \tilde{\mathbf{T}} & \mathbf{0} \\ \mathbf{0} & \tilde{\mathbf{T}} \end{bmatrix} \quad (29)$$

The nodal forces are transformed in the same way,

$$\mathbf{f}' = \mathbf{T} \mathbf{f} \quad (30)$$

Stiffness Matrix in the 2-D Space

In the local coordinate system, we have

$$\frac{EA}{L} \begin{bmatrix} 1 & -1 \\ -1 & 1 \end{bmatrix} \begin{Bmatrix} u'_i \\ u'_j \end{Bmatrix} = \begin{Bmatrix} f'_i \\ f'_j \end{Bmatrix}$$

Augmenting this equation, we write

$$\frac{EA}{L} \begin{bmatrix} 1 & 0 & -1 & 0 \\ 0 & 0 & 0 & 0 \\ -1 & 0 & 1 & 0 \\ 0 & 0 & 0 & 0 \end{bmatrix} \begin{Bmatrix} u'_i \\ v'_i \\ u'_j \\ v'_j \end{Bmatrix} = \begin{Bmatrix} f'_i \\ 0 \\ f'_j \\ 0 \end{Bmatrix}$$

or,

$$\mathbf{k}' \mathbf{u}' = \mathbf{f}'$$

Using transformations given in (29) and (30), we obtain

$$\mathbf{k}' \mathbf{T} \mathbf{u} = \mathbf{T} \mathbf{f}$$

Multiplying both sides by \mathbf{T}^T and noticing that $\mathbf{T}^T \mathbf{T} = \mathbf{I}$, we obtain

$$\mathbf{T}^T \mathbf{k}' \mathbf{T} \mathbf{u} = \mathbf{f} \tag{31}$$

Thus, the element stiffness matrix \mathbf{k} in the global coordinate system is

$$\mathbf{k} = \mathbf{T}^T \mathbf{k}' \mathbf{T} \tag{32}$$

which is a 4×4 symmetric matrix.

Explicit form,

$$\mathbf{k} = \frac{EA}{L} \begin{bmatrix} & u_i & v_i & u_j & v_j \\ l^2 & lm & -l^2 & -lm \\ lm & m^2 & -lm & -m^2 \\ -l^2 & -lm & l^2 & lm \\ -lm & -m^2 & lm & m^2 \end{bmatrix} \quad (33)$$

Calculation of the *directional cosines* l and m :

$$l = \cos \theta = \frac{X_j - X_i}{L}, \quad m = \sin \theta = \frac{Y_j - Y_i}{L} \quad (34)$$

The structure stiffness matrix is assembled by using the element stiffness matrices in the usual way as in the 1-D case.

Element Stress

$$\sigma = E\varepsilon = E\mathbf{B} \begin{Bmatrix} u_i \\ v_i \\ u_j \\ v_j \end{Bmatrix} = E \begin{bmatrix} -\frac{1}{L} & \frac{1}{L} \\ 0 & 0 \end{bmatrix} \begin{bmatrix} l & m & 0 & 0 \\ 0 & 0 & l & m \end{bmatrix} \begin{Bmatrix} u_i \\ v_i \\ u_j \\ v_j \end{Bmatrix}$$

That is,

$$\sigma = \frac{E}{L} \begin{bmatrix} -l & -m & l & m \end{bmatrix} \begin{Bmatrix} u_i \\ v_i \\ u_j \\ v_j \end{Bmatrix} \quad (35)$$

Example 2.3

A simple plane truss is made of two identical bars (with E , A , and L), and loaded as shown in the figure. Find

- 1) displacement of node 2;
- 2) stress in each bar.

Solution:

This simple structure is used here to demonstrate the assembly and solution process using the bar element in 2-D space.

In local coordinate systems, we have

$$\mathbf{k}'_1 = \frac{EA}{L} \begin{bmatrix} 1 & -1 \\ -1 & 1 \end{bmatrix} = \mathbf{k}'_2$$

These two matrices cannot be assembled together, because they are in different coordinate systems. We need to convert them to global coordinate system OXY .

Element 1:

$$\theta = 45^\circ, \quad l = m = \frac{\sqrt{2}}{2}$$

Using formula (32) or (33), we obtain the stiffness matrix in the global system

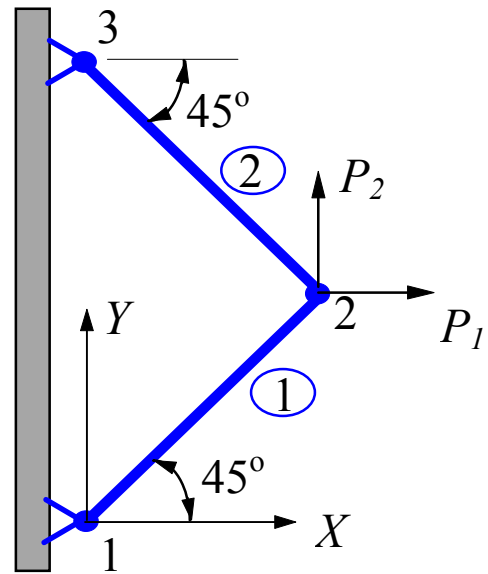

$$\mathbf{k}_1 = \mathbf{T}_1^T \mathbf{k}'_1 \mathbf{T}_1 = \frac{EA}{2L} \begin{matrix} & u_1 & v_1 & u_2 & v_2 \\ \begin{bmatrix} 1 & 1 & -1 & -1 \\ 1 & 1 & -1 & -1 \\ -1 & -1 & 1 & 1 \\ -1 & -1 & 1 & 1 \end{bmatrix} \end{matrix}$$

Element 2:

$$\theta = 135^\circ, \quad l = -\frac{\sqrt{2}}{2}, \quad m = \frac{\sqrt{2}}{2}$$

We have,

$$\mathbf{k}_2 = \mathbf{T}_2^T \mathbf{k}'_2 \mathbf{T}_2 = \frac{EA}{2L} \begin{matrix} & u_2 & v_2 & u_3 & v_3 \\ \begin{bmatrix} 1 & -1 & -1 & 1 \\ -1 & 1 & 1 & -1 \\ -1 & 1 & 1 & -1 \\ 1 & -1 & -1 & 1 \end{bmatrix} \end{matrix}$$

Assemble the structure FE equation,

$$\frac{EA}{2L} \begin{matrix} & u_1 & v_1 & u_2 & v_2 & u_3 & v_3 \\ \begin{bmatrix} 1 & 1 & -1 & -1 & 0 & 0 \\ 1 & 1 & -1 & -1 & 0 & 0 \\ -1 & -1 & 2 & 0 & -1 & 1 \\ -1 & -1 & 0 & 2 & 1 & -1 \\ 0 & 0 & -1 & 1 & 1 & -1 \\ 0 & 0 & 1 & -1 & -1 & 1 \end{bmatrix} \begin{Bmatrix} u_1 \\ v_1 \\ u_2 \\ v_2 \\ u_3 \\ v_3 \end{Bmatrix} = \begin{Bmatrix} F_{1X} \\ F_{1Y} \\ F_{2X} \\ F_{2Y} \\ F_{3X} \\ F_{3Y} \end{Bmatrix}$$

Load and boundary conditions (BC):

$$u_1 = v_1 = u_3 = v_3 = 0, \quad F_{2X} = P_1, \quad F_{2Y} = P_2$$

Condensed FE equation,

$$\frac{EA}{2L} \begin{bmatrix} 2 & 0 \\ 0 & 2 \end{bmatrix} \begin{Bmatrix} u_2 \\ v_2 \end{Bmatrix} = \begin{Bmatrix} P_1 \\ P_2 \end{Bmatrix}$$

Solving this, we obtain the displacement of node 2,

$$\begin{Bmatrix} u_2 \\ v_2 \end{Bmatrix} = \frac{L}{EA} \begin{Bmatrix} P_1 \\ P_2 \end{Bmatrix}$$

Using formula (35), we calculate the stresses in the two bars,

$$\sigma_1 = \frac{E \sqrt{2}}{L} \begin{bmatrix} -1 & -1 & 1 & 1 \end{bmatrix} \frac{L}{EA} \begin{Bmatrix} 0 \\ 0 \\ P_1 \\ P_2 \end{Bmatrix} = \frac{\sqrt{2}}{2A} (P_1 + P_2)$$

$$\sigma_2 = \frac{E \sqrt{2}}{L} \begin{bmatrix} 1 & -1 & -1 & 1 \end{bmatrix} \frac{L}{EA} \begin{Bmatrix} P_1 \\ P_2 \\ 0 \\ 0 \end{Bmatrix} = \frac{\sqrt{2}}{2A} (P_1 - P_2)$$

Check the results:

Look for the equilibrium conditions, symmetry, antisymmetry, etc.

Example 2.4 (Multipoint Constraint)

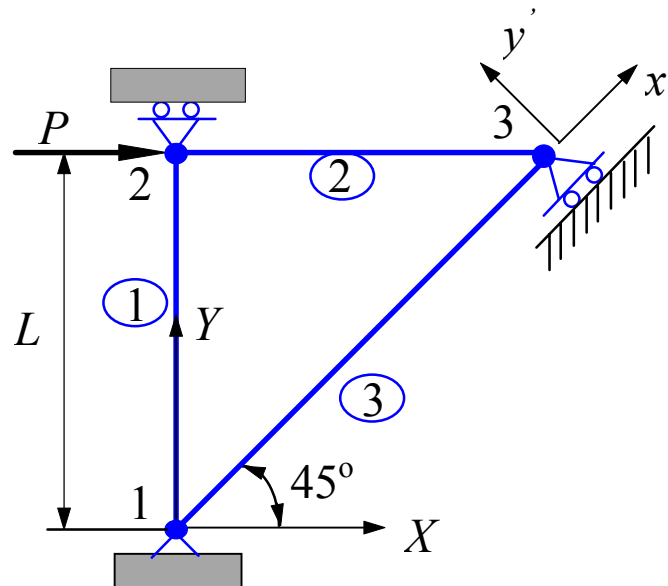

For the plane truss shown above,

$$P = 1000 \text{ kN}, \quad L = 1 \text{ m}, \quad E = 210 \text{ GPa},$$

$$A = 6.0 \times 10^{-4} \text{ m}^2 \quad \text{for elements 1 and 2,}$$

$$A = 6\sqrt{2} \times 10^{-4} \text{ m}^2 \quad \text{for element 3.}$$

Determine the displacements and reaction forces.

Solution:

We have an inclined roller at node 3, which needs special attention in the FE solution. We first assemble the global FE equation for the truss.

Element 1:

$$\theta = 90^\circ, \quad l = 0, \quad m = 1$$

$$\mathbf{k}_1 = \frac{(210 \times 10^9)(6.0 \times 10^{-4})}{1} \begin{bmatrix} u_1 & v_1 & u_2 & v_2 \\ 0 & 0 & 0 & 0 \\ 0 & 1 & 0 & -1 \\ 0 & 0 & 0 & 0 \\ 0 & -1 & 0 & 1 \end{bmatrix} \text{ (N / m)}$$

Element 2:

$$\theta = 0^\circ, \quad l = 1, \quad m = 0$$

$$\mathbf{k}_2 = \frac{(210 \times 10^9)(6.0 \times 10^{-4})}{1} \begin{bmatrix} u_2 & v_2 & u_3 & v_3 \\ 1 & 0 & -1 & 0 \\ 0 & 0 & 0 & 0 \\ -1 & 0 & 1 & 0 \\ 0 & 0 & 0 & 0 \end{bmatrix} \text{ (N / m)}$$

Element 3:

$$\theta = 45^\circ, \quad l = \frac{1}{\sqrt{2}}, \quad m = \frac{1}{\sqrt{2}}$$

$$\mathbf{k}_3 = \frac{(210 \times 10^9)(6\sqrt{2} \times 10^{-4})}{\sqrt{2}} \begin{bmatrix} u_1 & v_1 & u_3 & v_3 \\ 0.5 & 0.5 & -0.5 & -0.5 \\ 0.5 & 0.5 & -0.5 & -0.5 \\ -0.5 & -0.5 & 0.5 & 0.5 \\ -0.5 & -0.5 & 0.5 & 0.5 \end{bmatrix} \text{ (N / m)}$$

The global FE equation is,

$$1260 \times 10^5 \begin{bmatrix} 0.5 & 0.5 & 0 & 0 & -0.5 & -0.5 \\ & 1.5 & 0 & -1 & -0.5 & -0.5 \\ & & 1 & 0 & -1 & 0 \\ & & & 1 & 0 & 0 \\ & & & & 1.5 & 0.5 \\ \text{Sym.} & & & & & 0.5 \end{bmatrix} \begin{Bmatrix} u_1 \\ v_1 \\ u_2 \\ v_2 \\ u_3 \\ v_3 \end{Bmatrix} = \begin{Bmatrix} F_{1X} \\ F_{1Y} \\ F_{2X} \\ F_{2Y} \\ F_{3X} \\ F_{3Y} \end{Bmatrix}$$

Load and boundary conditions (BC):

$$u_1 = v_1 = v_2 = 0, \quad \text{and} \quad v_3' = 0, \\ F_{2X} = P, \quad F_{3x'} = 0.$$

From the transformation relation and the BC, we have

$$v_3' = \begin{bmatrix} -\frac{\sqrt{2}}{2} & \frac{\sqrt{2}}{2} \end{bmatrix} \begin{Bmatrix} u_3 \\ v_3 \end{Bmatrix} = \frac{\sqrt{2}}{2} (-u_3 + v_3) = 0,$$

that is,

$$u_3 - v_3 = 0$$

This is a *multipoint constraint* (MPC).

Similarly, we have a relation for the force at node 3,

$$F_{3x'} = \begin{bmatrix} \frac{\sqrt{2}}{2} & \frac{\sqrt{2}}{2} \end{bmatrix} \begin{Bmatrix} F_{3X} \\ F_{3Y} \end{Bmatrix} = \frac{\sqrt{2}}{2} (F_{3X} + F_{3Y}) = 0,$$

that is,

$$F_{3X} + F_{3Y} = 0$$

Applying the load and BC's in the structure FE equation by 'deleting' 1st, 2nd and 4th rows and columns, we have

$$1260 \times 10^5 \begin{bmatrix} 1 & -1 & 0 \\ -1 & 1.5 & 0.5 \\ 0 & 0.5 & 0.5 \end{bmatrix} \begin{Bmatrix} u_2 \\ u_3 \\ v_3 \end{Bmatrix} = \begin{Bmatrix} P \\ F_{3X} \\ F_{3Y} \end{Bmatrix}$$

Further, from the MPC and the force relation at node 3, the equation becomes,

$$1260 \times 10^5 \begin{bmatrix} 1 & -1 & 0 \\ -1 & 1.5 & 0.5 \\ 0 & 0.5 & 0.5 \end{bmatrix} \begin{Bmatrix} u_2 \\ u_3 \\ u_3 \end{Bmatrix} = \begin{Bmatrix} P \\ F_{3X} \\ -F_{3X} \end{Bmatrix}$$

which is

$$1260 \times 10^5 \begin{bmatrix} 1 & -1 \\ -1 & 2 \\ 0 & 1 \end{bmatrix} \begin{Bmatrix} u_2 \\ u_3 \end{Bmatrix} = \begin{Bmatrix} P \\ F_{3X} \\ -F_{3X} \end{Bmatrix}$$

The 3rd equation yields,

$$F_{3X} = -1260 \times 10^5 u_3$$

Substituting this into the 2nd equation and rearranging, we have

$$1260 \times 10^5 \begin{bmatrix} 1 & -1 \\ -1 & 3 \end{bmatrix} \begin{Bmatrix} u_2 \\ u_3 \end{Bmatrix} = \begin{Bmatrix} P \\ 0 \end{Bmatrix}$$

Solving this, we obtain the displacements,

$$\begin{Bmatrix} u_2 \\ u_3 \end{Bmatrix} = \frac{1}{2520 \times 10^5} \begin{Bmatrix} 3P \\ P \end{Bmatrix} = \begin{Bmatrix} 0.01191 \\ 0.003968 \end{Bmatrix} \quad (\text{m})$$

From the global FE equation, we can calculate the reaction forces,

$$\begin{Bmatrix} F_{1X} \\ F_{1Y} \\ F_{2Y} \\ F_{3X} \\ F_{3Y} \end{Bmatrix} = 1260 \times 10^5 \begin{bmatrix} 0 & -0.5 & -0.5 \\ 0 & -0.5 & -0.5 \\ 0 & 0 & 0 \\ -1 & 1.5 & 0.5 \\ 0 & 0.5 & 0.5 \end{bmatrix} \begin{Bmatrix} u_2 \\ u_3 \\ v_3 \end{Bmatrix} = \begin{Bmatrix} -500 \\ -500 \\ 0.0 \\ -500 \\ 500 \end{Bmatrix} \quad (\text{kN})$$

Check the results!

A general *multipoint constraint* (MPC) can be described as,

$$\sum_j A_j u_j = 0$$

where A_j 's are constants and u_j 's are nodal displacement components. In the FE software, such as *MSC/NASTRAN*, users only need to specify this relation to the software. The software will take care of the solution.

Penalty Approach for Handling BC's and MPC's

3-D Case

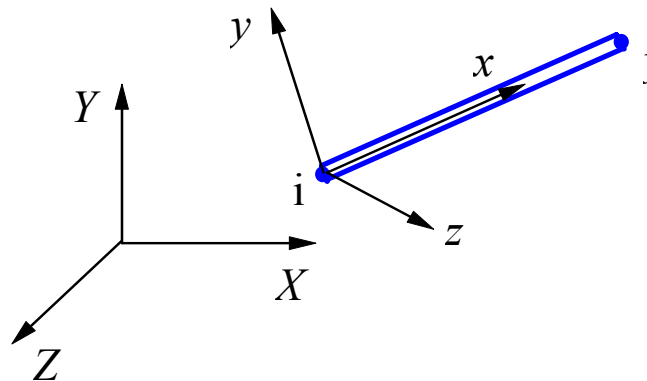

<i>Local</i>	<i>Global</i>
x, y, z	X, Y, Z
u'_i, v'_i, w'_i	u_i, v_i, w_i
1 dof at node	3 dof's at node

Element stiffness matrices are calculated in the local coordinate systems and then transformed into the global coordinate system (X, Y, Z) where they are assembled.

FEA software packages will do this transformation automatically.

Input data for bar elements:

- (X, Y, Z) for each node
- E and A for each element

III. Beam Element

Simple Plane Beam Element

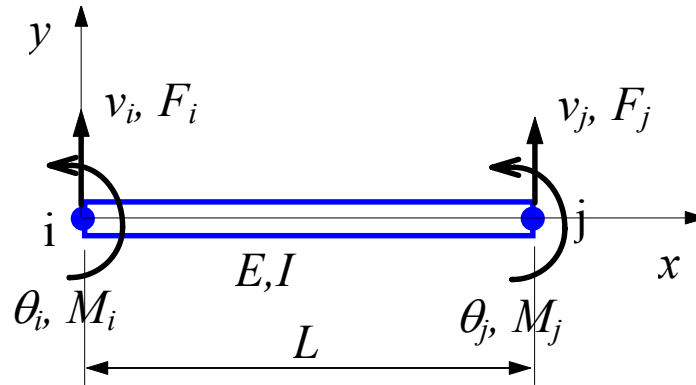

L	length
I	moment of inertia of the cross-sectional area
E	elastic modulus
$v = v(x)$	deflection (lateral displacement) of the neutral axis
$\theta = \frac{dv}{dx}$	rotation about the z-axis
$F = F(x)$	shear force
$M = M(x)$	moment about z-axis

Elementary Beam Theory:

$$EI \frac{d^2v}{dx^2} = M(x) \quad (36)$$

$$\sigma = -\frac{My}{I} \quad (37)$$

Direct Method

Using the results from elementary beam theory to compute each column of the stiffness matrix.

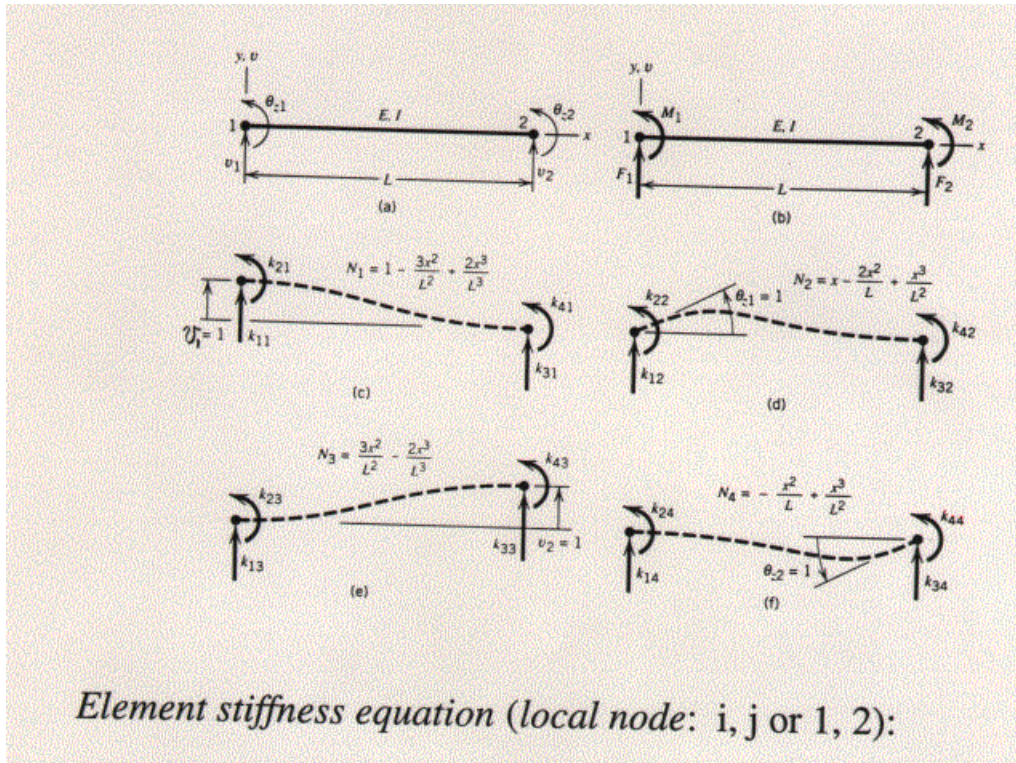

(Fig. 2.3-1. on Page 21 of Cook's Book)

Element stiffness equation (local node: i, j or 1, 2):

$$\frac{EI}{L^3} \begin{bmatrix} 12 & 6L & -12 & 6L \\ 6L & 4L^2 & -6L & 2L^2 \\ -12 & -6L & 12 & -6L \\ 6L & 2L^2 & -6L & 4L^2 \end{bmatrix} \begin{Bmatrix} v_i \\ \theta_i \\ v_j \\ \theta_j \end{Bmatrix} = \begin{Bmatrix} F_i \\ M_i \\ F_j \\ M_j \end{Bmatrix} \quad (38)$$

Formal Approach

Apply the formula,

$$\mathbf{k} = \int_0^L \mathbf{B}^T E I \mathbf{B} dx \quad (39)$$

To derive this, we introduce the shape functions,

$$\begin{aligned} N_1(x) &= 1 - 3x^2 / L^2 + 2x^3 / L^3 \\ N_2(x) &= x - 2x^2 / L + x^3 / L^2 \\ N_3(x) &= 3x^2 / L^2 - 2x^3 / L^3 \\ N_4(x) &= -x^2 / L + x^3 / L^2 \end{aligned} \quad (40)$$

Then, we can represent the deflection as,

$$\begin{aligned} v(x) &= \mathbf{N} \mathbf{u} \\ &= [N_1(x) \quad N_2(x) \quad N_3(x) \quad N_4(x)] \begin{Bmatrix} v_i \\ \theta_i \\ v_j \\ \theta_j \end{Bmatrix} \end{aligned} \quad (41)$$

which is a cubic function. Notice that,

$$\begin{aligned} N_1 + N_3 &= 1 \\ N_2 + N_3 L + N_4 &= x \end{aligned}$$

which implies that the rigid body motion is represented by the assumed deformed shape of the beam.

Curvature of the beam is,

$$\frac{d^2 v}{dx^2} = \frac{d^2}{dx^2} \mathbf{N} \mathbf{u} = \mathbf{B} \mathbf{u} \quad (42)$$

where the strain-displacement matrix \mathbf{B} is given by,

$$\begin{aligned} \mathbf{B} &= \frac{d^2}{dx^2} \mathbf{N} = \left[N_1''(x) \quad N_2''(x) \quad N_3''(x) \quad N_4''(x) \right] \\ &= \left[-\frac{6}{L^2} + \frac{12x}{L^3} \quad -\frac{4}{L} + \frac{6x}{L^2} \quad \frac{6}{L^2} - \frac{12x}{L^3} \quad -\frac{2}{L} + \frac{6x}{L^2} \right] \end{aligned} \quad (43)$$

Strain energy stored in the beam element is

$$\begin{aligned} U &= \frac{1}{2} \int_V \boldsymbol{\sigma}^T \boldsymbol{\varepsilon} dV = \frac{1}{2} \int_0^L \int_A \left(-\frac{My}{I} \right)^T \frac{1}{E} \left(-\frac{My}{I} \right) dA dx \\ &= \frac{1}{2} \int_0^L M^T \frac{1}{EI} M dx = \frac{1}{2} \int_0^L \left(\frac{d^2 v}{dx^2} \right)^T EI \left(\frac{d^2 v}{dx^2} \right) dx \\ &= \frac{1}{2} \int_0^L (\mathbf{B} \mathbf{u})^T EI (\mathbf{B} \mathbf{u}) dx \\ &= \frac{1}{2} \mathbf{u}^T \left(\int_0^L \mathbf{B}^T EI \mathbf{B} dx \right) \mathbf{u} \end{aligned}$$

We conclude that the stiffness matrix for the simple beam element is

$$\mathbf{k} = \int_0^L \mathbf{B}^T EI \mathbf{B} dx$$

Applying the result in (43) and carrying out the integration, we arrive at the same stiffness matrix as given in (38).

Combining the axial stiffness (bar element), we obtain the stiffness matrix of a *general 2-D beam element*,

$$\mathbf{k} = \begin{bmatrix} \frac{EA}{L} & 0 & 0 & -\frac{EA}{L} & 0 & 0 \\ 0 & \frac{12EI}{L^3} & \frac{6EI}{L^2} & 0 & -\frac{12EI}{L^3} & \frac{6EI}{L^2} \\ 0 & \frac{6EI}{L^2} & \frac{4EI}{L} & 0 & -\frac{6EI}{L^2} & \frac{2EI}{L} \\ -\frac{EA}{L} & 0 & 0 & \frac{EA}{L} & 0 & 0 \\ 0 & -\frac{12EI}{L^3} & -\frac{6EI}{L^2} & 0 & \frac{12EI}{L^3} & -\frac{6EI}{L^2} \\ 0 & \frac{6EI}{L^2} & \frac{2EI}{L} & 0 & -\frac{6EI}{L^2} & \frac{4EI}{L} \end{bmatrix}$$

3-D Beam Element

The element stiffness matrix is formed in the local (2-D) coordinate system first and then transformed into the global (3-D) coordinate system to be assembled.

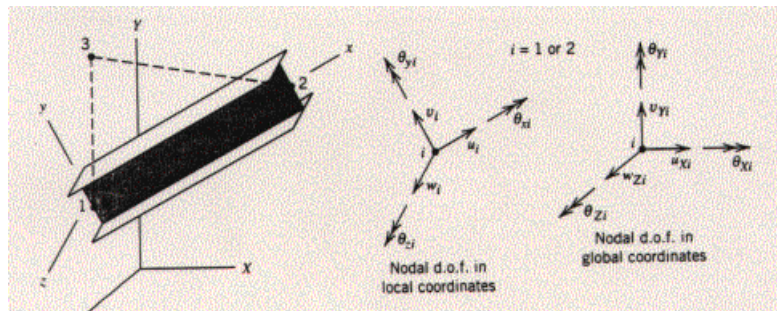

(Fig. 2.3-2. On Page 24 of Cook's book)

Example 2.5

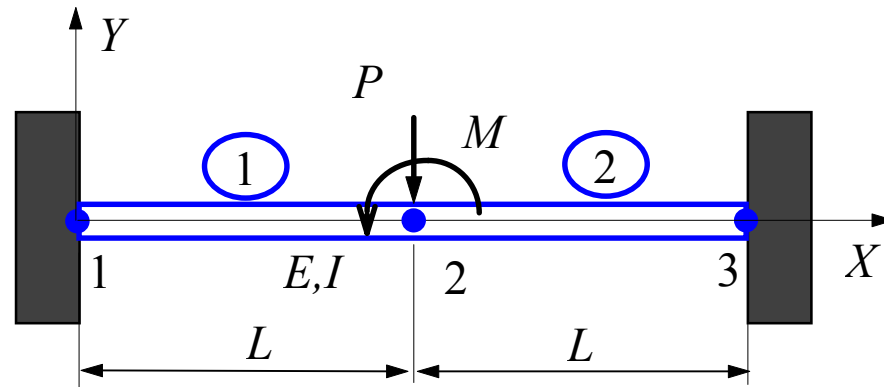

Given: The beam shown above is clamped at the two ends and acted upon by the force P and moment M in the mid-span.

Find: The deflection and rotation at the center node and the reaction forces and moments at the two ends.

Solution: Element stiffness matrices are,

$$\mathbf{k}_1 = \frac{EI}{L^3} \begin{bmatrix} v_1 & \theta_1 & v_2 & \theta_2 \\ 12 & 6L & -12 & 6L \\ 6L & 4L^2 & -6L & 2L^2 \\ -12 & -6L & 12 & -6L \\ 6L & 2L^2 & -6L & 4L^2 \end{bmatrix}$$

$$\mathbf{k}_2 = \frac{EI}{L^3} \begin{bmatrix} v_2 & \theta_2 & v_3 & \theta_3 \\ 12 & 6L & -12 & 6L \\ 6L & 4L^2 & -6L & 2L^2 \\ -12 & -6L & 12 & -6L \\ 6L & 2L^2 & -6L & 4L^2 \end{bmatrix}$$

Global FE equation is,

$$\frac{EI}{L^3} \begin{bmatrix} v_1 & \theta_1 & v_2 & \theta_2 & v_3 & \theta_3 \\ 12 & 6L & -12 & 6L & 0 & 0 \\ 6L & 4L^2 & -6L & 2L^2 & 0 & 0 \\ -12 & -6L & 24 & 0 & -12 & 6L \\ 6L & 2L^2 & 0 & 8L^2 & -6L & 2L^2 \\ 0 & 0 & -12 & -6L & 12 & -6L \\ 0 & 0 & 6L & 2L^2 & -6L & 4L^2 \end{bmatrix} \begin{Bmatrix} v_1 \\ \theta_1 \\ v_2 \\ \theta_2 \\ v_3 \\ \theta_3 \end{Bmatrix} = \begin{Bmatrix} F_{1Y} \\ M_1 \\ F_{2Y} \\ M_2 \\ F_{3Y} \\ M_3 \end{Bmatrix}$$

Loads and constraints (BC's) are,

$$F_{2Y} = -P, \quad M_2 = M, \\ v_1 = v_3 = \theta_1 = \theta_3 = 0$$

Reduced FE equation,

$$\frac{EI}{L^3} \begin{bmatrix} 24 & 0 \\ 0 & 8L^2 \end{bmatrix} \begin{Bmatrix} v_2 \\ \theta_2 \end{Bmatrix} = \begin{Bmatrix} -P \\ M \end{Bmatrix}$$

Solving this we obtain,

$$\begin{Bmatrix} v_2 \\ \theta_2 \end{Bmatrix} = \frac{L}{24EI} \begin{Bmatrix} -PL^2 \\ 3M \end{Bmatrix}$$

From global FE equation, we obtain the reaction forces and moments,

$$\begin{Bmatrix} F_{1Y} \\ M_1 \\ F_{3Y} \\ M_3 \end{Bmatrix} = \frac{EI}{L^3} \begin{bmatrix} -12 & 6L \\ -6L & 2L^2 \\ -12 & -6L \\ 6L & 2L^2 \end{bmatrix} \begin{Bmatrix} v_2 \\ \theta_2 \end{Bmatrix} = \frac{1}{4} \begin{Bmatrix} 2P + 3M/L \\ PL + M \\ 2P - 3M/L \\ -PL + M \end{Bmatrix}$$

Stresses in the beam at the two ends can be calculated using the formula,

$$\sigma = \sigma_x = -\frac{My}{I}$$

Note that the FE solution is exact according to the simple beam theory, since no distributed load is present between the nodes. Recall that,

$$EI \frac{d^2v}{dx^2} = M(x)$$

and

$$\frac{dM}{dx} = V \quad (V - \text{shear force in the beam})$$

$$\frac{dV}{dx} = q \quad (q - \text{distributed load on the beam})$$

Thus,

$$EI \frac{d^4v}{dx^4} = q(x)$$

If $q(x)=0$, then exact solution for the deflection v is a cubic function of x , which is what described by our shape functions.

Equivalent Nodal Loads of Distributed Transverse Load

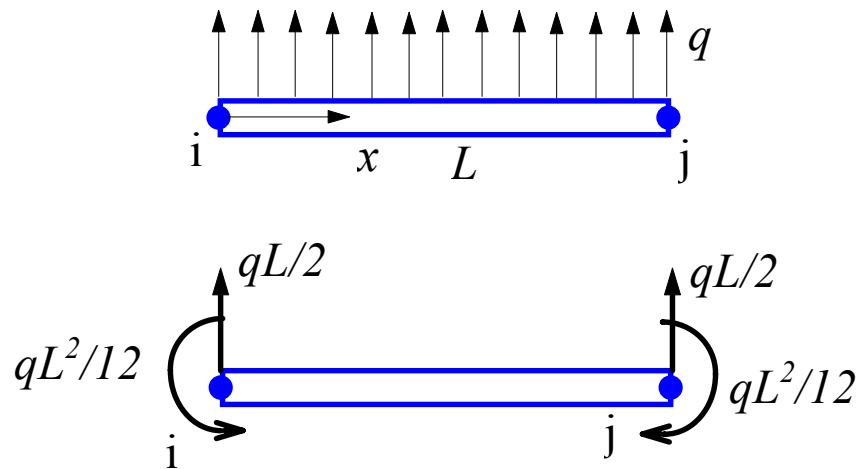

This can be verified by considering the work done by the distributed load q .

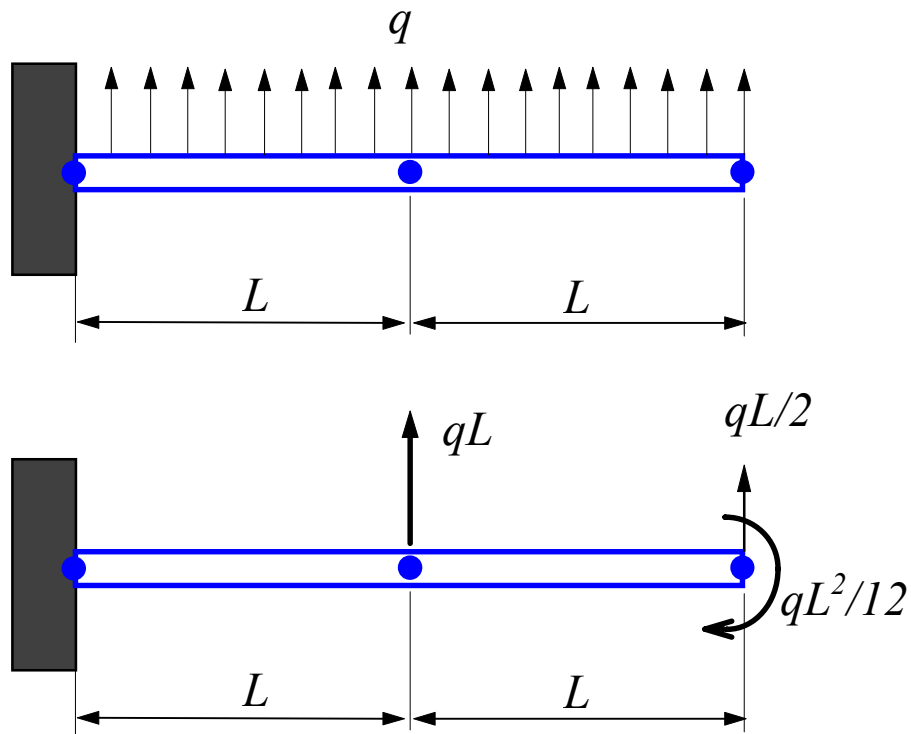

Example 2.6

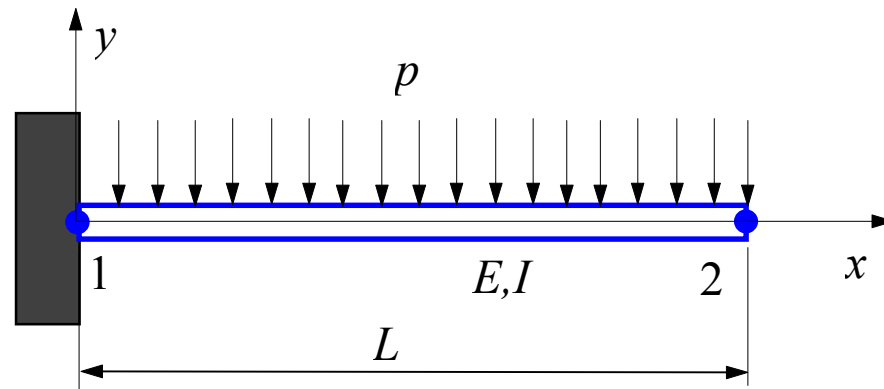

Given: A cantilever beam with distributed lateral load p as shown above.

Find: The deflection and rotation at the right end, the reaction force and moment at the left end.

Solution: The work-equivalent nodal loads are shown below,

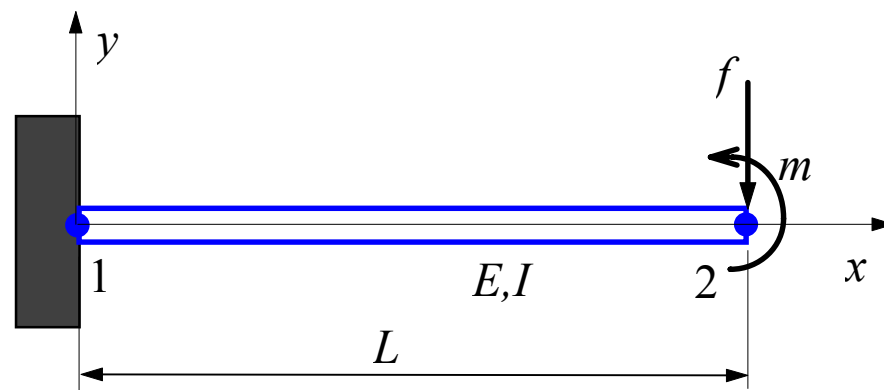

where

$$f = pL / 2, \quad m = pL^2 / 12$$

Applying the FE equation, we have

$$\frac{EI}{L^3} \begin{bmatrix} 12 & 6L & -12 & 6L \\ 6L & 4L^2 & -6L & 2L^2 \\ -12 & -6L & 12 & -6L \\ 6L & 2L^2 & -6L & 4L^2 \end{bmatrix} \begin{Bmatrix} v_1 \\ \theta_1 \\ v_2 \\ \theta_2 \end{Bmatrix} = \begin{Bmatrix} F_{1Y} \\ M_1 \\ F_{2Y} \\ M_2 \end{Bmatrix}$$

Load and constraints (BC's) are,

$$F_{2Y} = -f, \quad M_2 = m$$

$$v_1 = \theta_1 = 0$$

Reduced equation is,

$$\frac{EI}{L^3} \begin{bmatrix} 12 & -6L \\ -6L & 4L^2 \end{bmatrix} \begin{Bmatrix} v_2 \\ \theta_2 \end{Bmatrix} = \begin{Bmatrix} -f \\ m \end{Bmatrix}$$

Solving this, we obtain,

$$\begin{Bmatrix} v_2 \\ \theta_2 \end{Bmatrix} = \frac{L}{6EI} \begin{Bmatrix} -2L^2 f + 3Lm \\ -3Lf + 6m \end{Bmatrix} = \begin{Bmatrix} -pL^4 / 8EI \\ -pL^3 / 6EI \end{Bmatrix} \quad (\text{A})$$

These nodal values are the same as the exact solution. Note that the deflection $v(x)$ (for $0 < x < L$) in the beam by the FEM is, however, different from that by the exact solution. The exact solution by the simple beam theory is a 4th order polynomial of x , while the FE solution of v is only a 3rd order polynomial of x .

If the equivalent moment m is ignored, we have,

$$\begin{Bmatrix} v_2 \\ \theta_2 \end{Bmatrix} = \frac{L}{6EI} \begin{Bmatrix} -2L^2 f \\ -3Lf \end{Bmatrix} = \begin{Bmatrix} -pL^4 / 6EI \\ -pL^3 / 4EI \end{Bmatrix} \quad (\text{B})$$

The errors in (B) will decrease if more elements are used. The

equivalent moment m is often ignored in the FEM applications. The FE solutions still converge as more elements are applied.

From the FE equation, we can calculate the reaction force and moment as,

$$\begin{Bmatrix} F_{1Y} \\ M_1 \end{Bmatrix} = \frac{L^3}{EI} \begin{bmatrix} -12 & 6L \\ -6L & 2L^2 \end{bmatrix} \begin{Bmatrix} v_2 \\ \theta_2 \end{Bmatrix} = \begin{Bmatrix} pL/2 \\ 5pL^2/12 \end{Bmatrix}$$

where the result in (A) is used. This force vector gives the total *effective nodal forces* which include the equivalent nodal forces for the distributed lateral load p given by,

$$\begin{Bmatrix} -pL/2 \\ -pL^2/12 \end{Bmatrix}$$

The correct *reaction forces* can be obtained as follows,

$$\begin{Bmatrix} F_{1Y} \\ M_1 \end{Bmatrix} = \begin{Bmatrix} pL/2 \\ 5pL^2/12 \end{Bmatrix} - \begin{Bmatrix} -pL/2 \\ -pL^2/12 \end{Bmatrix} = \begin{Bmatrix} pL \\ pL^2/2 \end{Bmatrix}$$

Check the results!

Example 2.7

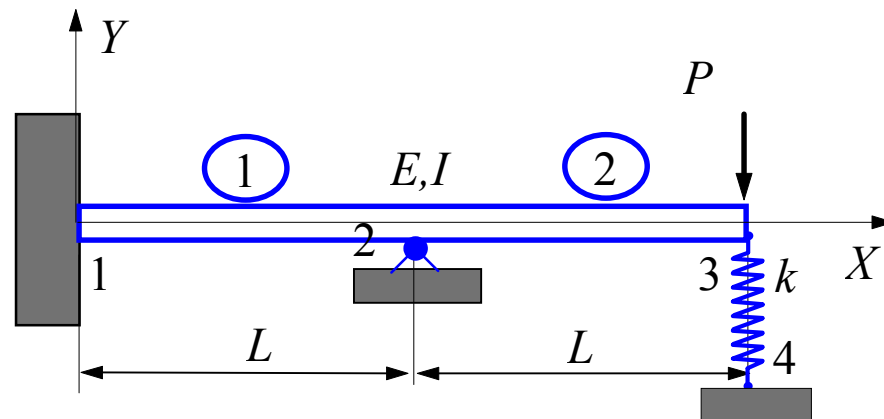

Given: $P = 50 \text{ kN}$, $k = 200 \text{ kN/m}$, $L = 3 \text{ m}$,

$E = 210 \text{ GPa}$, $I = 2 \times 10^{-4} \text{ m}^4$.

Find: Deflections, rotations and reaction forces.

Solution:

The beam has a roller (or hinge) support at node 2 and a spring support at node 3. We use two beam elements and one spring element to solve this problem.

The spring stiffness matrix is given by,

$$\mathbf{k}_s = \begin{bmatrix} & v_3 & v_4 \\ k & -k \\ -k & k \end{bmatrix}$$

Adding this stiffness matrix to the global FE equation (see *Example 2.5*), we have

$$\frac{EI}{L^3} \begin{bmatrix} v_1 & \theta_1 & v_2 & \theta_2 & v_3 & \theta_3 & v_4 \\ 12 & 6L & -12 & 6L & 0 & 0 & 0 \\ & 4L^2 & -6L & 2L^2 & 0 & 0 & 0 \\ & & 24 & 0 & -12 & 6L & 0 \\ & & & 8L^2 & -6L & 2L^2 & 0 \\ & & & & 12+k' & -6L & -k' \\ & & & & & 4L^2 & 0 \\ & & & & & & k' \end{bmatrix} \begin{Bmatrix} v_1 \\ \theta_1 \\ v_2 \\ \theta_2 \\ v_3 \\ \theta_3 \\ v_4 \end{Bmatrix} = \begin{Bmatrix} F_{1Y} \\ M_1 \\ F_{2Y} \\ M_2 \\ F_{3Y} \\ M_3 \\ F_{4Y} \end{Bmatrix}$$

Symmetry

in which

$$k' = \frac{L^3}{EI} k$$

is used to simplify the notation.

We now apply the boundary conditions,

$$\begin{aligned} v_1 = \theta_1 = v_2 = v_4 = 0, \\ M_2 = M_3 = 0, \quad F_{3Y} = -P \end{aligned}$$

‘Deleting’ the first three and seventh equations (rows and columns), we have the following reduced equation,

$$\frac{EI}{L^3} \begin{bmatrix} 8L^2 & -6L & 2L^2 \\ -6L & 12+k' & -6L \\ 2L^2 & -6L & 4L^2 \end{bmatrix} \begin{Bmatrix} \theta_2 \\ v_3 \\ \theta_3 \end{Bmatrix} = \begin{Bmatrix} 0 \\ -P \\ 0 \end{Bmatrix}$$

Solving this equation, we obtain the deflection and rotations at node 2 and node 3,

$$\begin{Bmatrix} \theta_2 \\ v_3 \\ \theta_3 \end{Bmatrix} = -\frac{PL^2}{EI(12 + 7k')} \begin{Bmatrix} 3 \\ 7L \\ 9 \end{Bmatrix}$$

The influence of the spring k is easily seen from this result. Plugging in the given numbers, we can calculate

$$\begin{Bmatrix} \theta_2 \\ v_3 \\ \theta_3 \end{Bmatrix} = \begin{Bmatrix} -0.002492 \text{ rad} \\ -0.01744 \text{ m} \\ -0.007475 \text{ rad} \end{Bmatrix}$$

From the global FE equation, we obtain the nodal reaction forces as,

$$\begin{Bmatrix} F_{1Y} \\ M_1 \\ F_{2Y} \\ F_{4Y} \end{Bmatrix} = \begin{Bmatrix} -69.78 \text{ kN} \\ -69.78 \text{ kN} \cdot \text{m} \\ 116.2 \text{ kN} \\ 3.488 \text{ kN} \end{Bmatrix}$$

Checking the results: Draw *free body diagram* of the beam

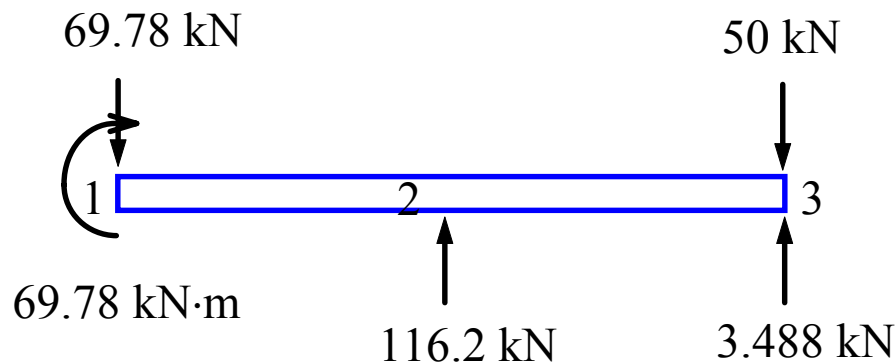

FE Analysis of Frame Structures

Members in a frame are considered to be rigidly connected. Both forces and moments can be transmitted through their joints. We need the *general beam element* (combinations of bar and simple beam elements) to model frames.

Example 2.8

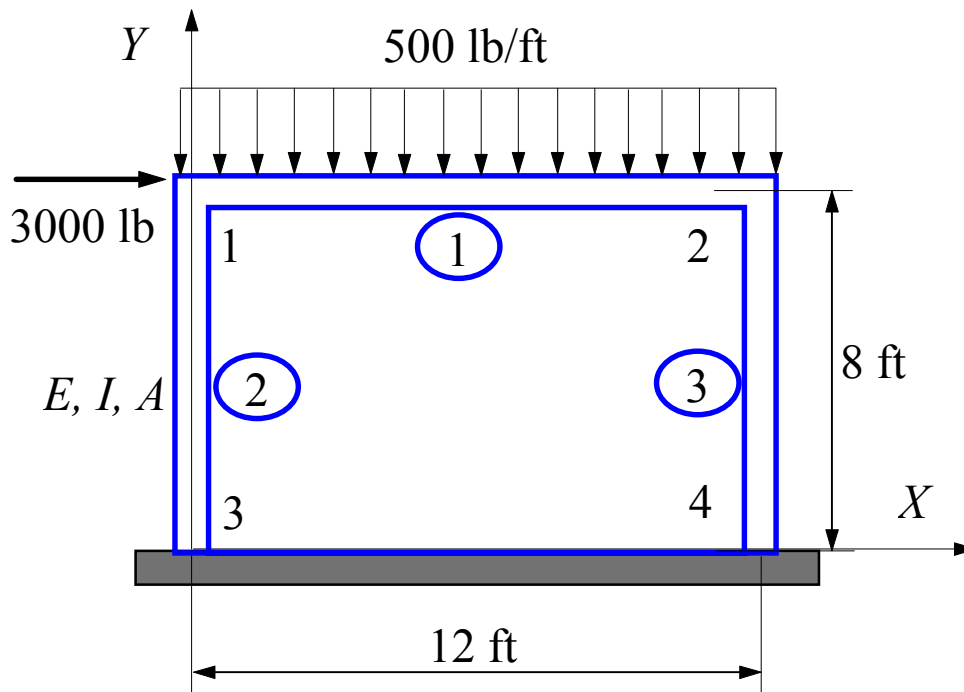

Given: $E = 30 \times 10^6$ psi, $I = 65$ in.⁴, $A = 6.8$ in.²

Find: Displacements and rotations of the two joints 1 and 2.

Solution:

For this example, we first convert the distributed load to its equivalent nodal loads.

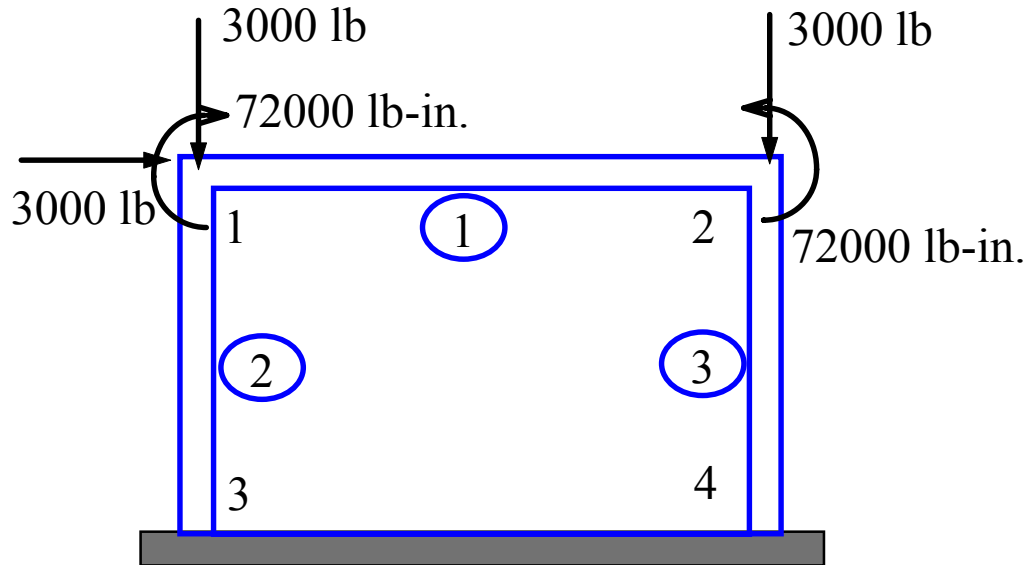

In *local coordinate system*, the stiffness matrix for a general 2-D beam element is

$$\mathbf{k} = \begin{bmatrix} \frac{EA}{L} & 0 & 0 & -\frac{EA}{L} & 0 & 0 \\ 0 & \frac{12EI}{L^3} & \frac{6EI}{L^2} & 0 & -\frac{12EI}{L^3} & \frac{6EI}{L^2} \\ 0 & \frac{6EI}{L^2} & \frac{4EI}{L} & 0 & -\frac{6EI}{L^2} & \frac{2EI}{L} \\ -\frac{EA}{L} & 0 & 0 & \frac{EA}{L} & 0 & 0 \\ 0 & -\frac{12EI}{L^3} & -\frac{6EI}{L^2} & 0 & \frac{12EI}{L^3} & -\frac{6EI}{L^2} \\ 0 & \frac{6EI}{L^2} & \frac{2EI}{L} & 0 & -\frac{6EI}{L^2} & \frac{4EI}{L} \end{bmatrix}$$

Element Connectivity Table

<i>Element</i>	<i>Node i (1)</i>	<i>Node j (2)</i>
1	1	2
2	3	1
3	4	2

For element 1, we have

$$\mathbf{k}_1 = \mathbf{k}_1' = 10^4 \times \begin{bmatrix} u_1 & v_1 & \theta_1 & u_2 & v_2 & \theta_2 \\ 141.7 & 0 & 0 & -141.7 & 0 & 0 \\ 0 & 0.784 & 56.4 & 0 & -0.784 & 56.4 \\ 0 & 56.4 & 5417 & 0 & -56.4 & 2708 \\ -141.7 & 0 & 0 & 141.7 & 0 & 0 \\ 0 & -0.784 & -56.4 & 0 & 0.784 & -56.4 \\ 0 & 56.4 & 2708 & 0 & -56.4 & 5417 \end{bmatrix}$$

For elements 2 and 3, the stiffness matrix in *local system* is,

$$\mathbf{k}_2' = \mathbf{k}_3' = 10^4 \times \begin{bmatrix} u_i' & v_i' & \theta_i' & u_j' & v_j' & \theta_j' \\ 212.5 & 0 & 0 & -212.5 & 0 & 0 \\ 0 & 2.65 & 127 & 0 & -2.65 & 127 \\ 0 & 127 & 8125 & 0 & -127 & 4063 \\ -212.5 & 0 & 0 & 212.5 & 0 & 0 \\ 0 & -2.65 & -127 & 0 & 2.65 & -127 \\ 0 & 127 & 4063 & 0 & -127 & 8125 \end{bmatrix}$$

where $i=3, j=1$ for element 2 and $i=4, j=2$ for element 3.

In general, the transformation matrix \mathbf{T} is,

$$\mathbf{T} = \begin{bmatrix} l & m & 0 & 0 & 0 & 0 \\ -m & l & 0 & 0 & 0 & 0 \\ 0 & 0 & 1 & 0 & 0 & 0 \\ 0 & 0 & 0 & l & m & 0 \\ 0 & 0 & 0 & -m & l & 0 \\ 0 & 0 & 0 & 0 & 0 & 1 \end{bmatrix}$$

We have

$$l = 0, \quad m = 1$$

for both elements 2 and 3. Thus,

$$\mathbf{T} = \begin{bmatrix} 0 & 1 & 0 & 0 & 0 & 0 \\ -1 & 0 & 0 & 0 & 0 & 0 \\ 0 & 0 & 1 & 0 & 0 & 0 \\ 0 & 0 & 0 & 0 & 1 & 0 \\ 0 & 0 & 0 & -1 & 0 & 0 \\ 0 & 0 & 0 & 0 & 0 & 1 \end{bmatrix}$$

Using the transformation relation,

$$\mathbf{k} = \mathbf{T}^T \mathbf{k}' \mathbf{T}$$

we obtain the stiffness matrices in the *global coordinate system* for elements 2 and 3,

$$\mathbf{k}_2 = 10^4 \times \begin{bmatrix} u_3 & v_3 & \theta_3 & u_1 & v_1 & \theta_1 \\ 2.65 & 0 & -127 & -2.65 & 0 & -127 \\ 0 & 212.5 & 0 & 0 & -212.5 & 0 \\ -127 & 0 & 8125 & 127 & 0 & 4063 \\ -2.65 & 0 & 127 & 2.65 & 0 & 127 \\ 0 & -212.5 & 0 & 0 & 212.5 & 0 \\ -127 & 0 & 4063 & 127 & 0 & 8125 \end{bmatrix}$$

and

$$\mathbf{k}_3 = 10^4 \times \begin{bmatrix} u_4 & v_4 & \theta_4 & u_2 & v_2 & \theta_2 \\ 2.65 & 0 & -127 & -2.65 & 0 & -127 \\ 0 & 212.5 & 0 & 0 & -212.5 & 0 \\ -127 & 0 & 8125 & 127 & 0 & 4063 \\ -2.65 & 0 & 127 & 2.65 & 0 & 127 \\ 0 & -212.5 & 0 & 0 & 212.5 & 0 \\ -127 & 0 & 4063 & 127 & 0 & 8125 \end{bmatrix}$$

Assembling the global FE equation and noticing the following boundary conditions,

$$\begin{aligned} u_3 &= v_3 = \theta_3 = u_4 = v_4 = \theta_4 = 0 \\ F_{1X} &= 3000\text{lb}, \quad F_{2X} = 0, \quad F_{1Y} = F_{2Y} = -3000\text{lb}, \\ M_1 &= -72000\text{lb}\cdot\text{in.}, \quad M_2 = 72000\text{lb}\cdot\text{in.} \end{aligned}$$

we obtain the condensed FE equation,

$$10^4 \times \begin{bmatrix} 144.3 & 0 & 127 & -141.7 & 0 & 0 \\ 0 & 213.3 & 56.4 & 0 & -0.784 & 56.4 \\ 127 & 56.4 & 13542 & 0 & -56.4 & 2708 \\ -141.7 & 0 & 0 & 144.3 & 0 & 127 \\ 0 & -0.784 & -56.4 & 0 & 213.3 & -56.4 \\ 0 & 56.4 & 2708 & 127 & -56.4 & 13542 \end{bmatrix} \begin{Bmatrix} u_1 \\ v_1 \\ \theta_1 \\ u_2 \\ v_2 \\ \theta_2 \end{Bmatrix} = \begin{Bmatrix} 3000 \\ -3000 \\ -72000 \\ 0 \\ -3000 \\ 72000 \end{Bmatrix}$$

Solving this, we get

$$\begin{Bmatrix} u_1 \\ v_1 \\ \theta_1 \\ u_2 \\ v_2 \\ \theta_2 \end{Bmatrix} = \begin{Bmatrix} 0.092 \text{ in.} \\ -0.00104 \text{ in.} \\ -0.00139 \text{ rad} \\ 0.0901 \text{ in.} \\ -0.0018 \text{ in.} \\ -3.88 \times 10^{-5} \text{ rad} \end{Bmatrix}$$

To calculate the reaction forces and moments at the two ends, we employ the element FE equations for element 2 and element 3. We obtain,

$$\begin{Bmatrix} F_{3X} \\ F_{3Y} \\ M_3 \end{Bmatrix} = \begin{Bmatrix} -672.7 \text{ lb} \\ 2210 \text{ lb} \\ 60364 \text{ lb}\cdot\text{in.} \end{Bmatrix}$$

and

$$\begin{Bmatrix} F_{4X} \\ F_{4Y} \\ M_4 \end{Bmatrix} = \begin{Bmatrix} -2338 \text{ lb} \\ 3825 \text{ lb} \\ 112641 \text{ lb}\cdot\text{in.} \end{Bmatrix}$$

Check the results:

Draw the free-body diagram of the frame. Equilibrium is maintained with the calculated forces and moments.

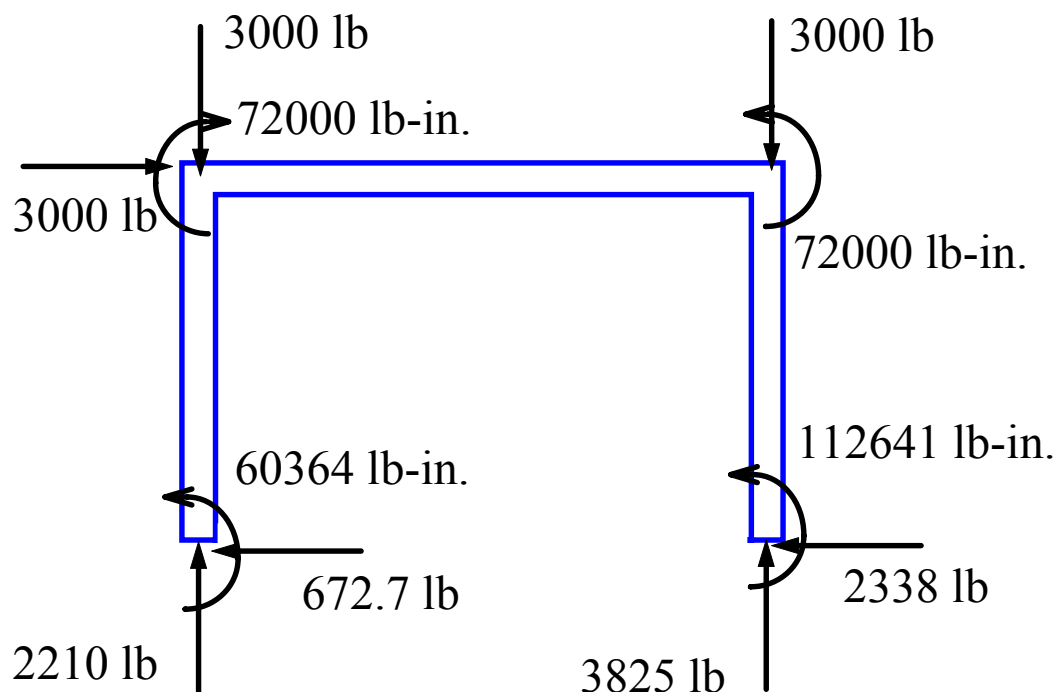

Chapter 3. Two-Dimensional Problems

I. Review of the Basic Theory

In general, the stresses and strains in a structure consist of six components:

$$\sigma_x, \sigma_y, \sigma_z, \tau_{xy}, \tau_{yz}, \tau_{zx} \quad \text{for stresses,}$$

and

$$\varepsilon_x, \varepsilon_y, \varepsilon_z, \gamma_{xy}, \gamma_{yz}, \gamma_{zx} \quad \text{for strains.}$$

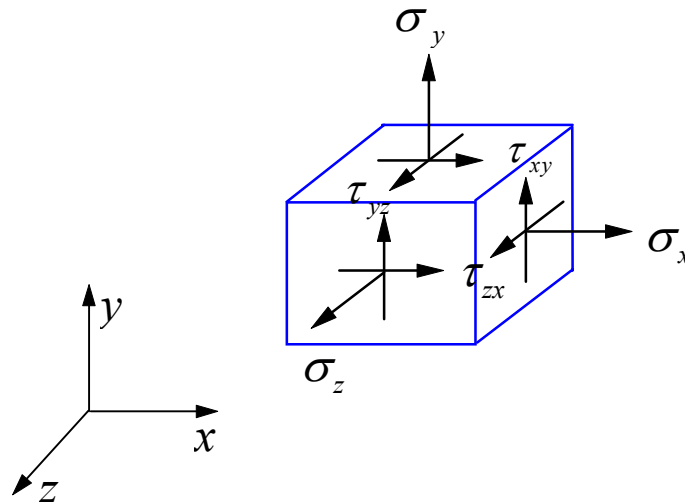

Under certain conditions, the state of stresses and strains can be simplified. A general 3-D structure analysis can, therefore, be reduced to a 2-D analysis.

Plane (2-D) Problems

- *Plane stress:*

$$\sigma_z = \tau_{yz} = \tau_{zx} = 0 \quad (\varepsilon_z \neq 0) \quad (1)$$

A thin planar structure with constant thickness and loading within the plane of the structure (xy -plane).

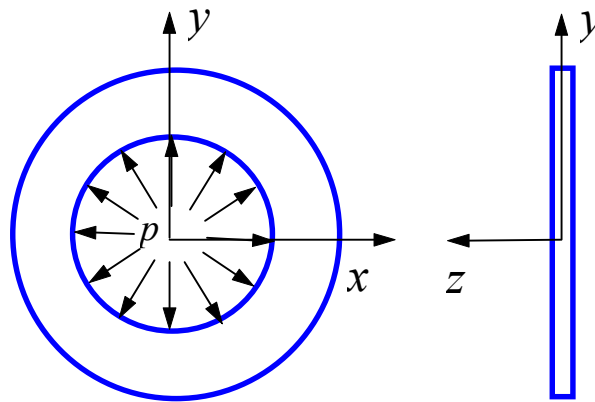

- *Plane strain:*

$$\varepsilon_z = \gamma_{yz} = \gamma_{zx} = 0 \quad (\sigma_z \neq 0) \quad (2)$$

A long structure with a uniform cross section and transverse loading along its length (z -direction).

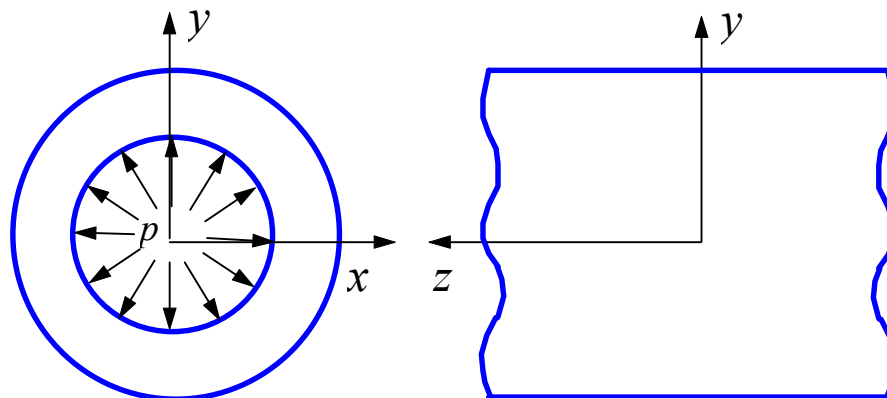

Stress-Strain-Temperature (Constitutive) Relations

For elastic and isotropic materials, we have,

$$\begin{Bmatrix} \varepsilon_x \\ \varepsilon_y \\ \gamma_{xy} \end{Bmatrix} = \begin{bmatrix} 1/E & -\nu/E & 0 \\ -\nu/E & 1/E & 0 \\ 0 & 0 & 1/G \end{bmatrix} \begin{Bmatrix} \sigma_x \\ \sigma_y \\ \tau_{xy} \end{Bmatrix} + \begin{Bmatrix} \varepsilon_{x0} \\ \varepsilon_{y0} \\ \gamma_{xy0} \end{Bmatrix} \quad (3)$$

or,

$$\varepsilon = \mathbf{E}^{-1} \sigma + \varepsilon_0$$

where ε_0 is the initial strain, E the Young's modulus, ν the Poisson's ratio and G the shear modulus. Note that,

$$G = \frac{E}{2(1+\nu)} \quad (4)$$

which means that there are only two independent material constants for *homogeneous* and *isotropic* materials.

We can also express stresses in terms of strains by solving the above equation,

$$\begin{Bmatrix} \sigma_x \\ \sigma_y \\ \tau_{xy} \end{Bmatrix} = \frac{E}{1-\nu^2} \begin{bmatrix} 1 & \nu & 0 \\ \nu & 1 & 0 \\ 0 & 0 & (1-\nu)/2 \end{bmatrix} \left(\begin{Bmatrix} \varepsilon_x \\ \varepsilon_y \\ \gamma_{xy} \end{Bmatrix} - \begin{Bmatrix} \varepsilon_{x0} \\ \varepsilon_{y0} \\ \gamma_{xy0} \end{Bmatrix} \right) \quad (5)$$

or,

$$\sigma = \mathbf{E} \varepsilon + \sigma_0$$

where $\sigma_0 = -\mathbf{E} \varepsilon_0$ is the initial stress.

The above relations are valid for *plane stress* case. For *plane strain* case, we need to replace the material constants in the above equations in the following fashion,

$$\begin{aligned} E &\rightarrow \frac{E}{1-\nu^2} \\ \nu &\rightarrow \frac{\nu}{1-\nu} \\ G &\rightarrow G \end{aligned} \quad (6)$$

For example, the stress is related to strain by

$$\begin{Bmatrix} \sigma_x \\ \sigma_y \\ \tau_{xy} \end{Bmatrix} = \frac{E}{(1+\nu)(1-2\nu)} \begin{bmatrix} 1-\nu & \nu & 0 \\ \nu & 1-\nu & 0 \\ 0 & 0 & (1-2\nu)/2 \end{bmatrix} \left(\begin{Bmatrix} \epsilon_x \\ \epsilon_y \\ \gamma_{xy} \end{Bmatrix} - \begin{Bmatrix} \epsilon_{x0} \\ \epsilon_{y0} \\ \gamma_{xy0} \end{Bmatrix} \right)$$

in the *plane strain* case.

Initial strains due to *temperature change* (thermal loading) is given by,

$$\begin{Bmatrix} \epsilon_{x0} \\ \epsilon_{y0} \\ \gamma_{xy0} \end{Bmatrix} = \begin{Bmatrix} \alpha\Delta T \\ \alpha\Delta T \\ 0 \end{Bmatrix} \quad (7)$$

where α is the coefficient of thermal expansion, ΔT the change of temperature. Note that if the structure is free to deform under thermal loading, there will be no (elastic) stresses in the structure.

Strain and Displacement Relations

For small strains and small rotations, we have,

$$\varepsilon_x = \frac{\partial u}{\partial x}, \quad \varepsilon_y = \frac{\partial v}{\partial y}, \quad \gamma_{xy} = \frac{\partial u}{\partial y} + \frac{\partial v}{\partial x}$$

In matrix form,

$$\begin{Bmatrix} \varepsilon_x \\ \varepsilon_y \\ \gamma_{xy} \end{Bmatrix} = \begin{bmatrix} \partial / \partial x & 0 \\ 0 & \partial / \partial y \\ \partial / \partial y & \partial / \partial x \end{bmatrix} \begin{Bmatrix} u \\ v \end{Bmatrix}, \quad \text{or } \boldsymbol{\varepsilon} = \mathbf{D}\mathbf{u} \quad (8)$$

From this relation, we know that the strains (and thus stresses) are one order lower than the displacements, if the displacements are represented by polynomials.

Equilibrium Equations

In elasticity theory, the stresses in the structure must satisfy the following equilibrium equations,

$$\begin{aligned} \frac{\partial \sigma_x}{\partial x} + \frac{\partial \tau_{xy}}{\partial y} + f_x &= 0 \\ \frac{\partial \tau_{xy}}{\partial x} + \frac{\partial \sigma_y}{\partial y} + f_y &= 0 \end{aligned} \quad (9)$$

where f_x and f_y are body forces (such as gravity forces) per unit volume. In FEM, these equilibrium conditions are satisfied in an approximate sense.

Boundary Conditions

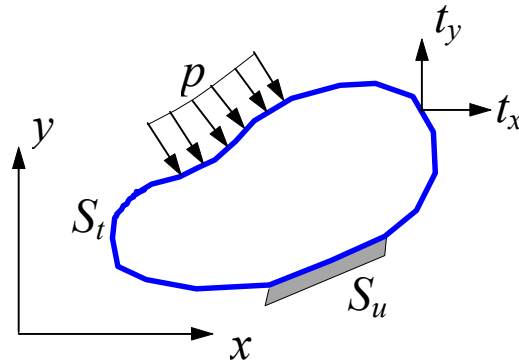

The boundary S of the body can be divided into two parts, S_u and S_t . The boundary conditions (BC's) are described as,

$$\begin{aligned} u &= \bar{u}, & v &= \bar{v}, & & \text{on } S_u \\ t_x &= \bar{t}_x, & t_y &= \bar{t}_y, & & \text{on } S_t \end{aligned} \quad (10)$$

in which t_x and t_y are traction forces (stresses on the boundary) and the barred quantities are those with known values.

In FEM, all types of loads (distributed surface loads, body forces, concentrated forces and moments, etc.) are converted to point forces acting at the nodes.

Exact Elasticity Solution

The exact solution (displacements, strains and stresses) of a given problem must satisfy the equilibrium equations (9), the given boundary conditions (10) and compatibility conditions (structures should deform in a continuous manner, no cracks or overlaps in the obtained displacement fields).

Example 3.1

A plate is supported and loaded with distributed force p as shown in the figure. The material constants are E and ν .

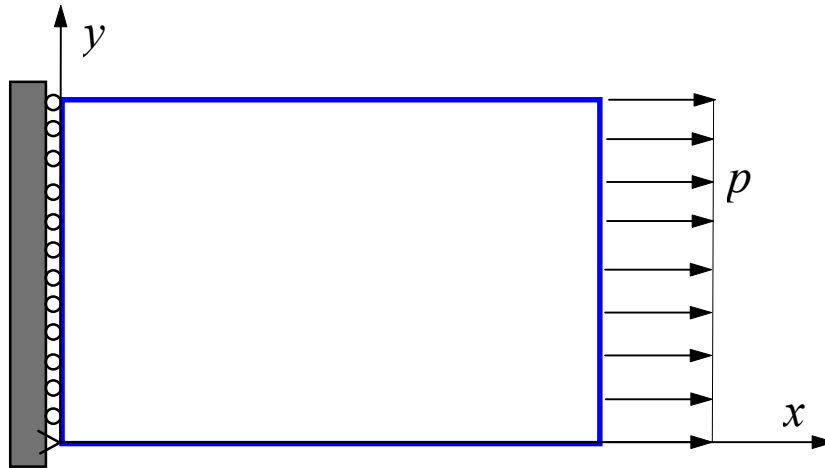

The exact solution for this simple problem can be found easily as follows,

Displacement:

$$u = \frac{p}{E}x, \quad v = -\nu \frac{p}{E}y$$

Strain:

$$\varepsilon_x = \frac{p}{E}, \quad \varepsilon_y = -\nu \frac{p}{E}, \quad \gamma_{xy} = 0$$

Stress:

$$\sigma_x = p, \quad \sigma_y = 0, \quad \tau_{xy} = 0$$

Exact (or analytical) solutions for *simple* problems are numbered (suppose there is a hole in the plate!). That is why we need FEM!

II. Finite Elements for 2-D Problems

A General Formula for the Stiffness Matrix

Displacements (u, v) in a plane element are interpolated from nodal displacements (u_i, v_i) using shape functions N_i as follows,

$$\begin{Bmatrix} u \\ v \end{Bmatrix} = \begin{bmatrix} N_1 & 0 & N_2 & 0 & \dots \\ 0 & N_1 & 0 & N_2 & \dots \end{bmatrix} \begin{Bmatrix} u_1 \\ v_1 \\ u_2 \\ v_2 \\ \vdots \end{Bmatrix} \quad \text{or} \quad \mathbf{u} = \mathbf{N}\mathbf{d} \quad (11)$$

where \mathbf{N} is the *shape function matrix*, \mathbf{u} the displacement vector and \mathbf{d} the *nodal* displacement vector. Here we have assumed that u depends on the nodal values of u only, and v on nodal values of v only.

From strain-displacement relation (Eq.(8)), the strain vector is,

$$\boldsymbol{\varepsilon} = \mathbf{D}\mathbf{u} = \mathbf{D}\mathbf{N}\mathbf{d}, \quad \text{or} \quad \boldsymbol{\varepsilon} = \mathbf{B}\mathbf{d} \quad (12)$$

where $\mathbf{B} = \mathbf{D}\mathbf{N}$ is the *strain-displacement matrix*.

Consider the strain energy stored in an element,

$$\begin{aligned}
 U &= \frac{1}{2} \int_V \boldsymbol{\sigma}^T \boldsymbol{\varepsilon} dV = \frac{1}{2} \int_V (\sigma_x \varepsilon_x + \sigma_y \varepsilon_y + \tau_{xy} \gamma_{xy}) dV \\
 &= \frac{1}{2} \int_V (\mathbf{E} \boldsymbol{\varepsilon})^T \boldsymbol{\varepsilon} dV = \frac{1}{2} \int_V \boldsymbol{\varepsilon}^T \mathbf{E} \boldsymbol{\varepsilon} dV \\
 &= \frac{1}{2} \mathbf{d}^T \int_V \mathbf{B}^T \mathbf{E} \mathbf{B} dV \mathbf{d} \\
 &= \frac{1}{2} \mathbf{d}^T \mathbf{k} \mathbf{d}
 \end{aligned}$$

From this, we obtain the general formula for the *element stiffness matrix*,

$$\mathbf{k} = \int_V \mathbf{B}^T \mathbf{E} \mathbf{B} dV \quad (13)$$

Note that unlike the 1-D cases, \mathbf{E} here is a *matrix* which is given by the stress-strain relation (e.g., Eq.(5) for plane stress).

The stiffness matrix \mathbf{k} defined by (13) is symmetric since \mathbf{E} is symmetric. Also note that given the material property, the behavior of \mathbf{k} depends on the \mathbf{B} matrix only, which in turn on the shape functions. Thus, the quality of finite elements in representing the behavior of a structure is entirely determined by the choice of shape functions.

Most commonly employed 2-D elements are linear or quadratic triangles and quadrilaterals.

Constant Strain Triangle (CST or T3)

This is the simplest 2-D element, which is also called *linear triangular element*.

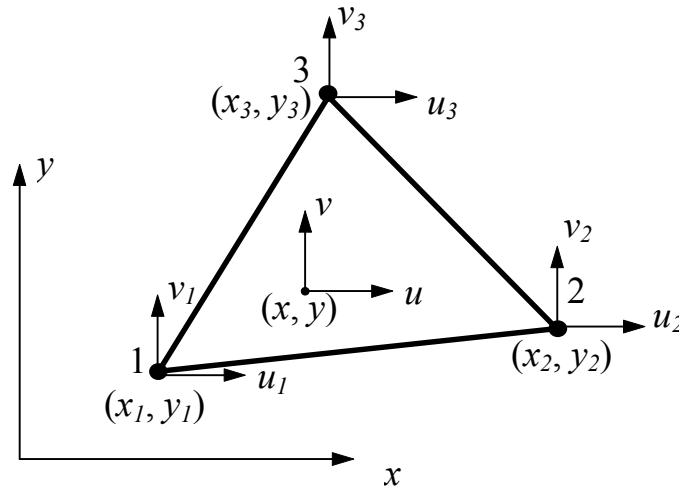

Linear Triangular Element

For this element, we have three nodes at the vertices of the triangle, which are numbered around the element in the counterclockwise direction. Each node has two degrees of freedom (can move in the x and y directions). The displacements u and v are assumed to be linear functions within the element, that is,

$$u = b_1 + b_2 x + b_3 y, \quad v = b_4 + b_5 x + b_6 y \quad (14)$$

where b_i ($i = 1, 2, \dots, 6$) are constants. From these, the strains are found to be,

$$\varepsilon_x = b_2, \quad \varepsilon_y = b_6, \quad \gamma_{xy} = b_3 + b_5 \quad (15)$$

which are constant throughout the element. Thus, we have the name “constant strain triangle” (CST).

Displacements given by (14) should satisfy the following six equations,

$$\begin{aligned} u_1 &= b_1 + b_2 x_1 + b_3 y_1 \\ u_2 &= b_1 + b_2 x_2 + b_3 y_2 \\ &\vdots \\ v_3 &= b_4 + b_5 x_3 + b_6 y_3 \end{aligned}$$

Solving these equations, we can find the coefficients b_1, b_2, \dots , and b_6 in terms of nodal displacements and coordinates. Substituting these coefficients into (14) and rearranging the terms, we obtain,

$$\begin{Bmatrix} u \\ v \end{Bmatrix} = \begin{bmatrix} N_1 & 0 & N_2 & 0 & N_3 & 0 \\ 0 & N_1 & 0 & N_2 & 0 & N_3 \end{bmatrix} \begin{Bmatrix} u_1 \\ v_1 \\ u_2 \\ v_2 \\ u_3 \\ v_3 \end{Bmatrix} \quad (16)$$

where the shape functions (linear functions in x and y) are

$$\begin{aligned} N_1 &= \frac{1}{2A} \{ (x_2 y_3 - x_3 y_2) + (y_2 - y_3)x + (x_3 - x_2)y \} \\ N_2 &= \frac{1}{2A} \{ (x_3 y_1 - x_1 y_3) + (y_3 - y_1)x + (x_1 - x_3)y \} \\ N_3 &= \frac{1}{2A} \{ (x_1 y_2 - x_2 y_1) + (y_1 - y_2)x + (x_2 - x_1)y \} \end{aligned} \quad (17)$$

and

$$A = \frac{1}{2} \det \begin{bmatrix} 1 & x_1 & y_1 \\ 1 & x_2 & y_2 \\ 1 & x_3 & y_3 \end{bmatrix} \quad (18)$$

is the area of the triangle (Prove this!).

Using the strain-displacement relation (8), results (16) and (17), we have,

$$\begin{Bmatrix} \varepsilon_x \\ \varepsilon_y \\ \gamma_{xy} \end{Bmatrix} = \mathbf{Bd} = \frac{1}{2A} \begin{bmatrix} y_{23} & 0 & y_{31} & 0 & y_{12} & 0 \\ 0 & x_{32} & 0 & x_{13} & 0 & x_{21} \\ x_{32} & y_{23} & x_{13} & y_{31} & x_{21} & y_{12} \end{bmatrix} \begin{Bmatrix} u_1 \\ v_1 \\ u_2 \\ v_2 \\ u_3 \\ v_3 \end{Bmatrix} \quad (19)$$

where $x_{ij} = x_i - x_j$ and $y_{ij} = y_i - y_j$ ($i, j = 1, 2, 3$). Again, we see constant strains within the element. From stress-strain relation (Eq.(5), for example), we see that stresses obtained using the CST element are also constant.

Applying formula (13), we obtain the element stiffness matrix for the CST element,

$$\mathbf{k} = \int_V \mathbf{B}^T \mathbf{E} \mathbf{B} dV = tA(\mathbf{B}^T \mathbf{E} \mathbf{B}) \quad (20)$$

in which t is the thickness of the element. Notice that \mathbf{k} for CST is a 6 by 6 *symmetric* matrix. The matrix multiplication in (20) can be carried out by a computer program.

Both the expressions of the shape functions in (17) and their derivations are lengthy and offer little insight into the behavior of the element.

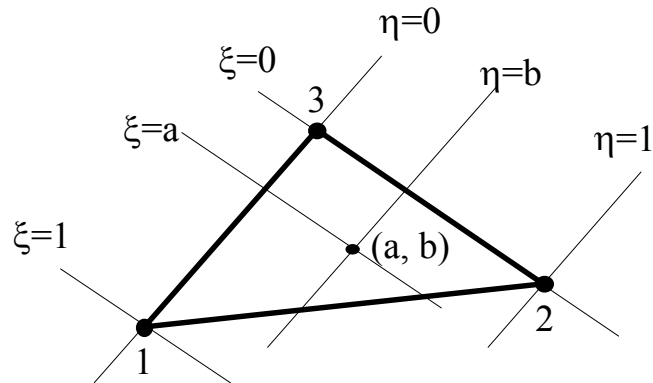

The Natural Coordinates

We introduce the *natural coordinates* (ξ, η) on the triangle, then *the shape functions* can be represented simply by,

$$N_1 = \xi, \quad N_2 = \eta, \quad N_3 = 1 - \xi - \eta \quad (21)$$

Notice that,

$$N_1 + N_2 + N_3 = 1 \quad (22)$$

which ensures that the rigid body translation is represented by the chosen shape functions. Also, as in the 1-D case,

$$N_i = \begin{cases} 1, & \text{at node } i; \\ 0, & \text{at the other nodes} \end{cases} \quad (23)$$

and varies linearly within the element. The plot for shape function N_1 is shown in the following figure. N_2 and N_3 have similar features.

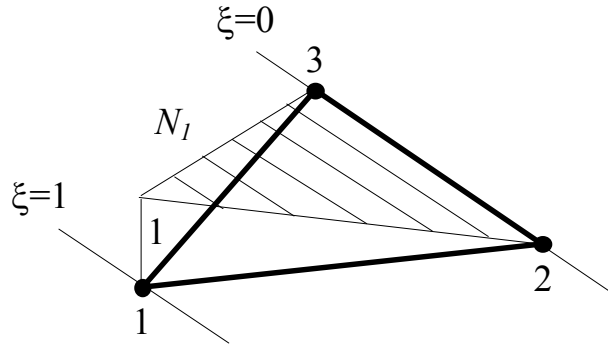

Shape Function N_1 for CST

We have two coordinate systems for the element: the global coordinates (x, y) and the natural coordinates (ξ, η) . The relation between the two is given by

$$\begin{aligned} x &= N_1 x_1 + N_2 x_2 + N_3 x_3 \\ y &= N_1 y_1 + N_2 y_2 + N_3 y_3 \end{aligned} \quad (24)$$

or,

$$\begin{aligned} x &= x_{13} \xi + x_{23} \eta + x_3 \\ y &= y_{13} \xi + y_{23} \eta + y_3 \end{aligned} \quad (25)$$

where $x_{ij} = x_i - x_j$ and $y_{ij} = y_i - y_j$ ($i, j = 1, 2, 3$) as defined earlier.

Displacement u or v on the element can be viewed as functions of (x, y) or (ξ, η) . Using the chain rule for derivatives, we have,

$$\begin{Bmatrix} \frac{\partial u}{\partial \xi} \\ \frac{\partial u}{\partial \eta} \end{Bmatrix} = \begin{bmatrix} \frac{\partial x}{\partial \xi} & \frac{\partial y}{\partial \xi} \\ \frac{\partial x}{\partial \eta} & \frac{\partial y}{\partial \eta} \end{bmatrix} \begin{Bmatrix} \frac{\partial u}{\partial x} \\ \frac{\partial u}{\partial y} \end{Bmatrix} = \mathbf{J} \begin{Bmatrix} \frac{\partial u}{\partial x} \\ \frac{\partial u}{\partial y} \end{Bmatrix} \quad (26)$$

where \mathbf{J} is called the *Jacobian matrix* of the transformation.

From (25), we calculate,

$$\mathbf{J} = \begin{bmatrix} x_{13} & y_{13} \\ x_{23} & y_{23} \end{bmatrix}, \quad \mathbf{J}^{-1} = \frac{1}{2A} \begin{bmatrix} y_{23} & -y_{13} \\ -x_{23} & x_{13} \end{bmatrix} \quad (27)$$

where $\det \mathbf{J} = x_{13}y_{23} - x_{23}y_{13} = 2A$ has been used (A is the area of the triangular element. Prove this!).

From (26), (27), (16) and (21) we have,

$$\begin{aligned} \begin{Bmatrix} \frac{\partial u}{\partial x} \\ \frac{\partial u}{\partial y} \end{Bmatrix} &= \frac{1}{2A} \begin{bmatrix} y_{23} & -y_{13} \\ -x_{23} & x_{13} \end{bmatrix} \begin{Bmatrix} \frac{\partial u}{\partial \xi} \\ \frac{\partial u}{\partial \eta} \end{Bmatrix} \\ &= \frac{1}{2A} \begin{bmatrix} y_{23} & -y_{13} \\ -x_{23} & x_{13} \end{bmatrix} \begin{Bmatrix} u_1 - u_3 \\ u_2 - u_3 \end{Bmatrix} \end{aligned} \quad (28)$$

Similarly,

$$\begin{Bmatrix} \frac{\partial v}{\partial x} \\ \frac{\partial v}{\partial y} \end{Bmatrix} = \frac{1}{2A} \begin{bmatrix} y_{23} & -y_{13} \\ -x_{23} & x_{13} \end{bmatrix} \begin{Bmatrix} v_1 - v_3 \\ v_2 - v_3 \end{Bmatrix} \quad (29)$$

Using the results in (28) and (29), and the relations $\boldsymbol{\varepsilon} = \mathbf{D}\mathbf{u} = \mathbf{D}\mathbf{N}\mathbf{d} = \mathbf{B}\mathbf{d}$, we obtain the strain-displacement matrix,

$$\mathbf{B} = \frac{1}{2A} \begin{bmatrix} y_{23} & 0 & y_{31} & 0 & y_{12} & 0 \\ 0 & x_{32} & 0 & x_{13} & 0 & x_{21} \\ x_{32} & y_{23} & x_{13} & y_{31} & x_{21} & y_{12} \end{bmatrix} \quad (30)$$

which is the same as we derived earlier in (19).

Applications of the CST Element:

- Use in areas where the strain gradient is small.
- Use in mesh transition areas (fine mesh to coarse mesh).
- Avoid using CST in stress concentration or other crucial areas in the structure, such as edges of holes and corners.
- Recommended for quick and preliminary FE analysis of 2-D problems.

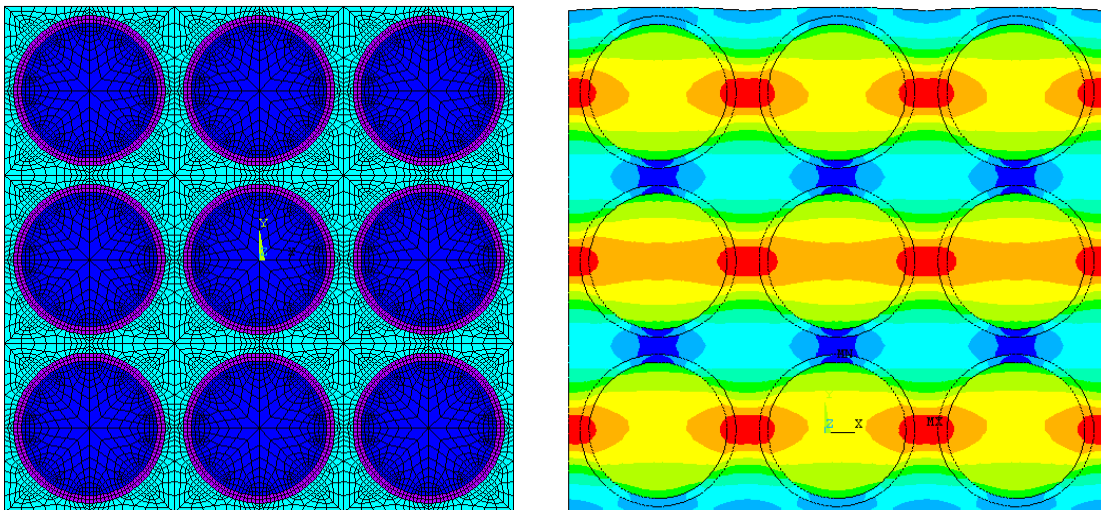

[Analysis of composite materials](#) (for which the CST is NOT appropriate!)

Linear Strain Triangle (LST or T6)

This element is also called *quadratic triangular element*.

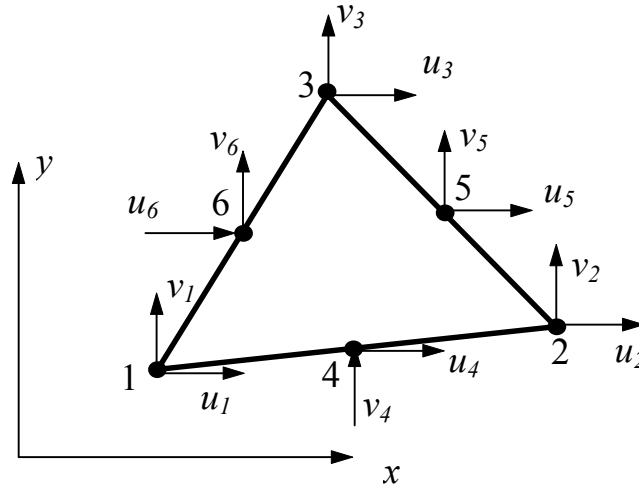

Quadratic Triangular Element

There are six nodes on this element: three corner nodes and three midside nodes. Each node has two degrees of freedom (DOF) as before. The displacements (u , v) are assumed to be quadratic functions of (x, y) ,

$$\begin{aligned} u &= b_1 + b_2x + b_3y + b_4x^2 + b_5xy + b_6y^2 \\ v &= b_7 + b_8x + b_9y + b_{10}x^2 + b_{11}xy + b_{12}y^2 \end{aligned} \quad (31)$$

where b_i ($i = 1, 2, \dots, 12$) are constants. From these, the strains are found to be,

$$\begin{aligned} \varepsilon_x &= b_2 + 2b_4x + b_5y \\ \varepsilon_y &= b_9 + b_{11}x + 2b_{12}y \\ \gamma_{xy} &= (b_3 + b_8) + (b_5 + 2b_{10})x + (2b_6 + b_{11})y \end{aligned} \quad (32)$$

which are linear functions. Thus, we have the “linear strain triangle” (LST), which provides better results than the CST.

In the natural coordinate system we defined earlier, the six shape functions for the LST element are,

$$\begin{aligned}
 N_1 &= \xi(2\xi - 1) \\
 N_2 &= \eta(2\eta - 1) \\
 N_3 &= \zeta(2\zeta - 1) \\
 N_4 &= 4\xi\eta \\
 N_5 &= 4\eta\zeta \\
 N_6 &= 4\zeta\xi
 \end{aligned} \tag{33}$$

in which $\zeta = 1 - \xi - \eta$. Each of these six shape functions represents a quadratic form on the element as shown in the figure.

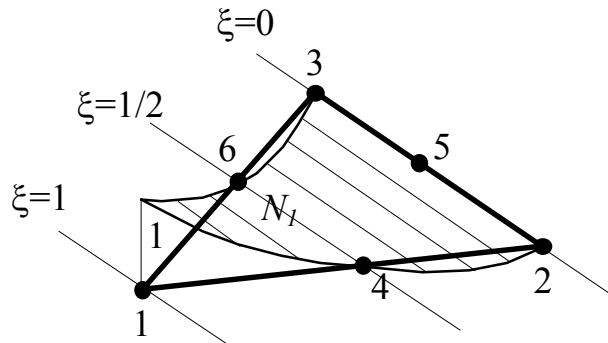

Shape Function N_1 for LST

Displacements can be written as,

$$u = \sum_{i=1}^6 N_i u_i, \quad v = \sum_{i=1}^6 N_i v_i \tag{34}$$

The element stiffness matrix is still given by $\mathbf{k} = \int_V \mathbf{B}^T \mathbf{E} \mathbf{B} dV$, but here $\mathbf{B}^T \mathbf{E} \mathbf{B}$ is quadratic in x and y . In general, the integral has to be computed numerically.

Linear Quadrilateral Element (Q4)

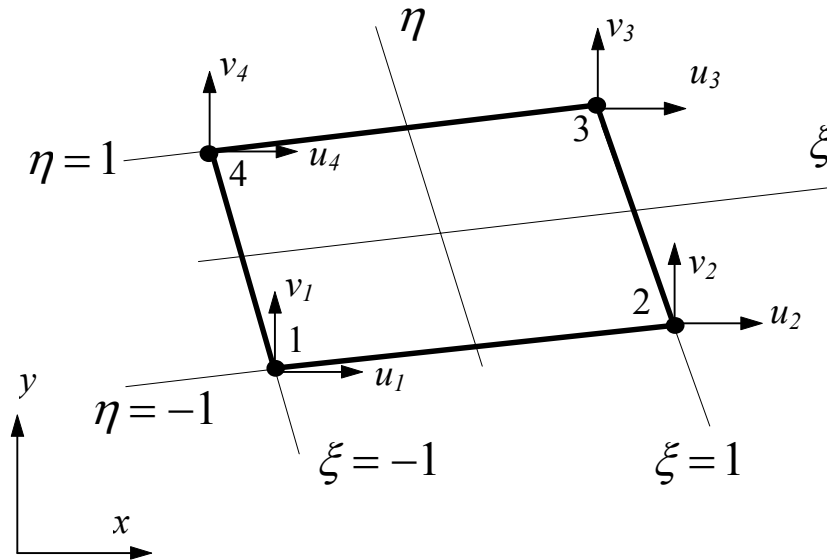

Linear Quadrilateral Element

There are four nodes at the corners of the quadrilateral shape. In the natural coordinate system (ξ, η) , the four shape functions are,

$$\begin{aligned} N_1 &= \frac{1}{4}(1 - \xi)(1 - \eta), & N_2 &= \frac{1}{4}(1 + \xi)(1 - \eta) \\ N_3 &= \frac{1}{4}(1 + \xi)(1 + \eta), & N_4 &= \frac{1}{4}(1 - \xi)(1 + \eta) \end{aligned} \quad (35)$$

Note that $\sum_{i=1}^4 N_i = 1$ at any point inside the element, as expected.

The displacement field is given by

$$u = \sum_{i=1}^4 N_i u_i, \quad v = \sum_{i=1}^4 N_i v_i \quad (36)$$

which are bilinear functions over the element.

Quadratic Quadrilateral Element (Q8)

This is the most widely used element for 2-D problems due to its high accuracy in analysis and flexibility in modeling.

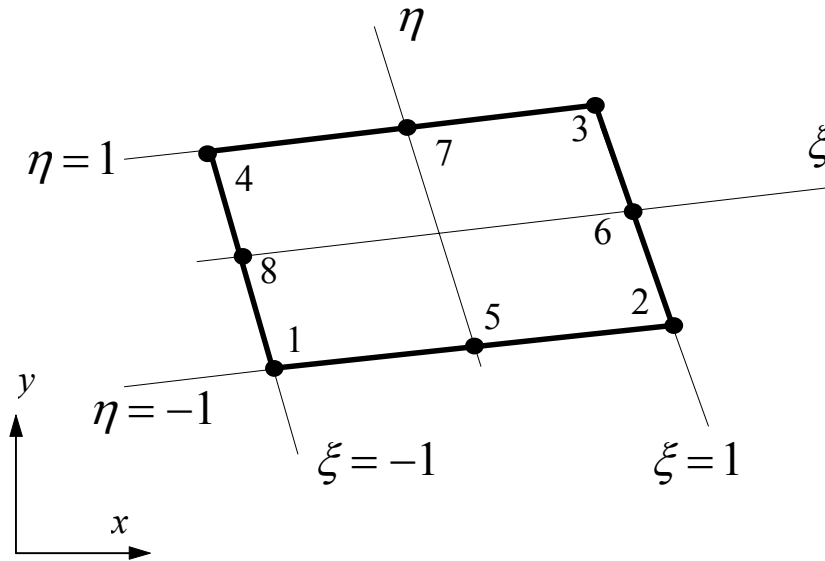

Quadratic Quadrilateral Element

There are eight nodes for this element, four corners nodes and four midside nodes. In the natural coordinate system (ξ, η) , the eight shape functions are,

$$\begin{aligned}
 N_1 &= \frac{1}{4}(1-\xi)(\eta-1)(\xi+\eta+1) \\
 N_2 &= \frac{1}{4}(1+\xi)(\eta-1)(\eta-\xi+1) \\
 N_3 &= \frac{1}{4}(1+\xi)(1+\eta)(\xi+\eta-1) \\
 N_4 &= \frac{1}{4}(\xi-1)(\eta+1)(\xi-\eta+1)
 \end{aligned} \tag{37}$$

$$N_5 = \frac{1}{2}(1 - \eta)(1 - \xi^2)$$

$$N_6 = \frac{1}{2}(1 + \xi)(1 - \eta^2)$$

$$N_7 = \frac{1}{2}(1 + \eta)(1 - \xi^2)$$

$$N_8 = \frac{1}{2}(1 - \xi)(1 - \eta^2)$$

Again, we have $\sum_{i=1}^8 N_i = 1$ at any point inside the element.

The displacement field is given by

$$u = \sum_{i=1}^8 N_i u_i, \quad v = \sum_{i=1}^8 N_i v_i \quad (38)$$

which are quadratic functions over the element. Strains and stresses over a quadratic quadrilateral element are linear functions, which are better representations.

Notes:

- Q4 and T3 are usually used together in a mesh with linear elements.
- Q8 and T6 are usually applied in a mesh composed of quadratic elements.
- Quadratic elements are preferred for stress analysis, because of their high accuracy and the flexibility in modeling complex geometry, such as curved boundaries.

Example 3.2

A square plate with a hole at the center and under pressure in one direction.

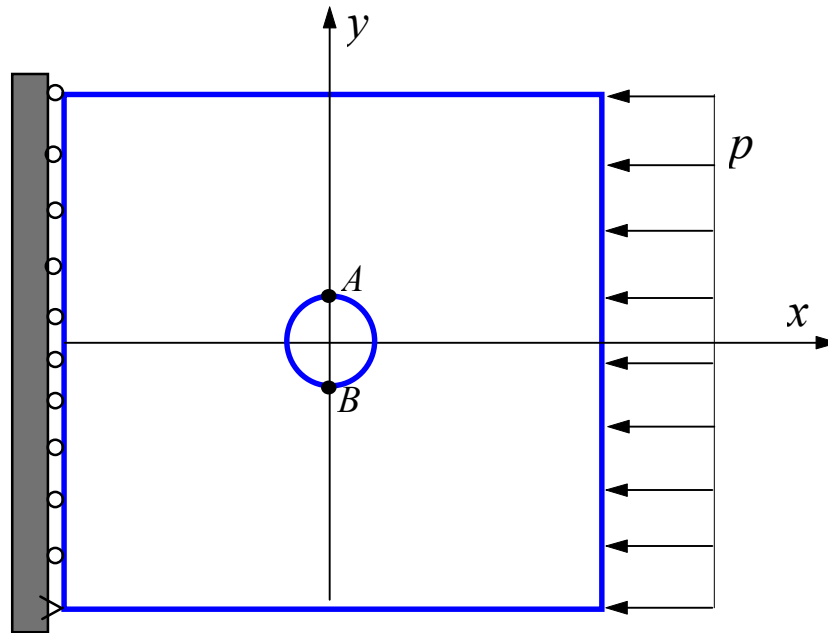

The dimension of the plate is 10 in. \times 10 in., thickness is 0.1 in. and radius of the hole is 1 in. Assume $E = 10 \times 10^6$ psi, $\nu = 0.3$ and $p = 100$ psi. Find the maximum stress in the plate.

FE Analysis:

From the knowledge of stress concentrations, we should expect the maximum stresses occur at points A and B on the edge of the hole. Value of this stress should be around $3p$ ($= 300$ psi) which is the exact solution for an infinitely large plate with a hole.

We use the *ANSYS* FEA software to do the modeling (meshing) and analysis, using quadratic triangular (T6 or LST), linear quadrilateral (Q4) and quadratic quadrilateral (Q8) elements. Linear triangles (CST or T3) is *NOT* available in *ANSYS*.

The stress calculations are listed in the following table, along with the number of elements and DOF used, for comparison.

Table. FEA Stress Results

<i>Elem. Type</i>	<i>No. Elem.</i>	<i>DOF</i>	<i>Max. σ (psi)</i>
T6	966	4056	310.1
Q4	493	1082	286.0
Q8	493	3150	327.1
...
Q8	2727	16,826	322.3

Discussions:

- Check the deformed shape of the plate
- Check convergence (use a finer mesh, if possible)
- Less elements (~ 100) should be enough to achieve the same accuracy with a better or “smarter” mesh
- We’ll redo this example in next chapter employing the symmetry conditions.

FEA Mesh (Q8, 493 elements)

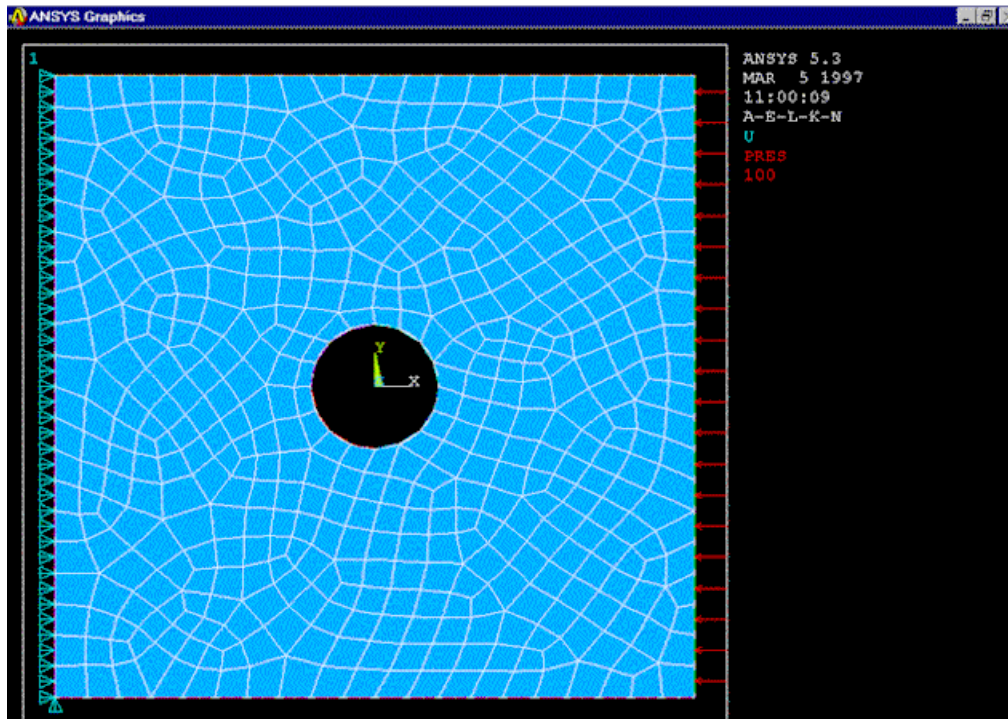

FEA Stress Plot (Q8, 493 elements)

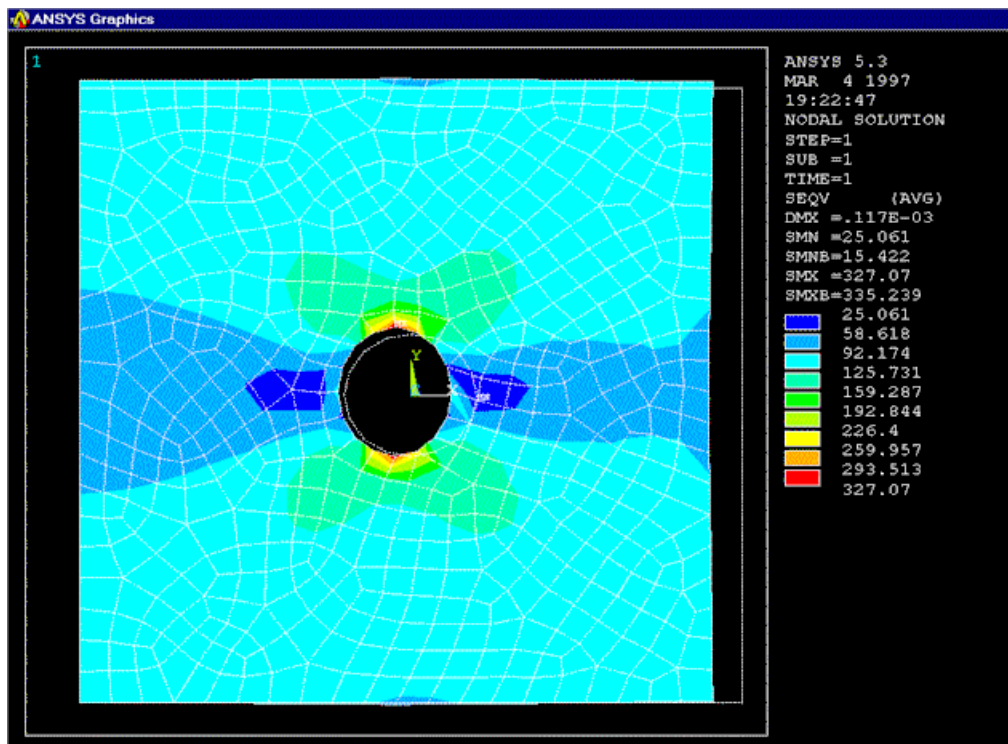

Transformation of Loads

Concentrated load (point forces), surface traction (pressure loads) and body force (weight) are the main types of loads applied to a structure. Both traction and body forces need to be converted to nodal forces in the FEA, since they cannot be applied to the FE model directly. The conversions of these loads are based on the same idea (the equivalent-work concept) which we have used for the cases of bar and beam elements.

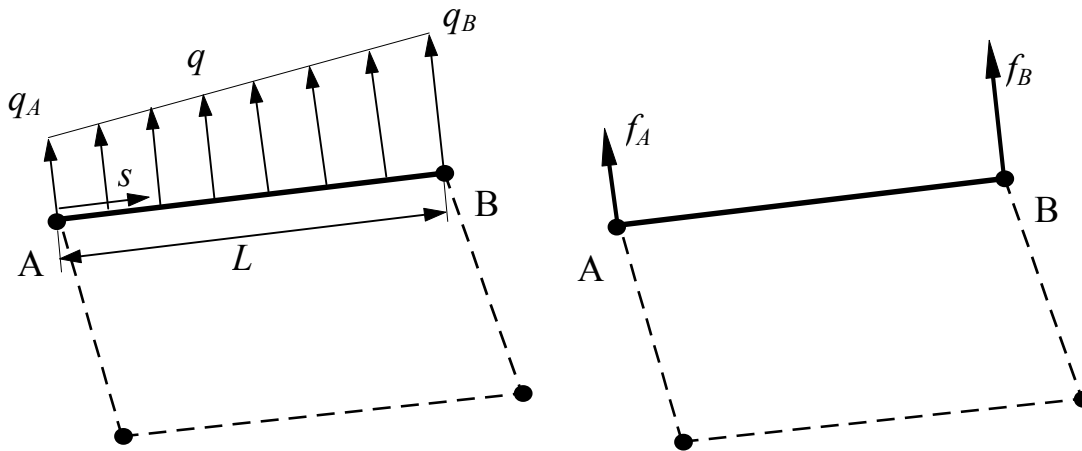

Traction on a Q4 element

Suppose, for example, we have a linearly varying traction q on a Q4 element edge, as shown in the figure. The traction is normal to the boundary. Using the local (tangential) coordinate s , we can write the work done by the traction q as,

$$W_q = t \int_0^L u_n(s) q(s) ds$$

where t is the thickness, L the side length and u_n the component of displacement normal to the edge AB .

For the Q4 element (linear displacement field), we have

$$u_n(s) = (1 - s/L)u_{nA} + (s/L)u_{nB}$$

The traction $q(s)$, which is also linear, is given in a similar way,

$$q(s) = (1 - s/L)q_A + (s/L)q_B$$

Thus, we have,

$$\begin{aligned} W_q &= t \int_0^L \left(\begin{bmatrix} u_{nA} & u_{nB} \end{bmatrix} \begin{bmatrix} 1 - s/L \\ s/L \end{bmatrix} \right) \left(\begin{bmatrix} 1 - s/L & s/L \end{bmatrix} \begin{bmatrix} q_A \\ q_B \end{bmatrix} \right) ds \\ &= \begin{bmatrix} u_{nA} & u_{nB} \end{bmatrix} t \int_0^L \begin{bmatrix} (1 - s/L)^2 & (s/L)(1 - s/L) \\ (s/L)(1 - s/L) & (s/L)^2 \end{bmatrix} ds \begin{bmatrix} q_A \\ q_B \end{bmatrix} \\ &= \begin{bmatrix} u_{nA} & u_{nB} \end{bmatrix} \frac{tL}{6} \begin{bmatrix} 2 & 1 \\ 1 & 2 \end{bmatrix} \begin{bmatrix} q_A \\ q_B \end{bmatrix} \end{aligned}$$

and the equivalent nodal force vector is,

$$\begin{Bmatrix} f_A \\ f_B \end{Bmatrix} = \frac{tL}{6} \begin{bmatrix} 2 & 1 \\ 1 & 2 \end{bmatrix} \begin{Bmatrix} q_A \\ q_B \end{Bmatrix}$$

Note, for constant q , we have,

$$\begin{Bmatrix} f_A \\ f_B \end{Bmatrix} = \frac{qtL}{2} \begin{Bmatrix} 1 \\ 1 \end{Bmatrix}$$

For quadratic elements (either triangular or quadrilateral), the traction is converted to forces at three nodes along the edge, instead of two nodes.

Traction tangent to the boundary, as well as body forces, are converted to nodal forces in a similar way.

Stress Calculation

The stress in an element is determined by the following relation,

$$\begin{Bmatrix} \sigma_x \\ \sigma_y \\ \tau_{xy} \end{Bmatrix} = \mathbf{E} \begin{Bmatrix} \varepsilon_x \\ \varepsilon_y \\ \gamma_{xy} \end{Bmatrix} = \mathbf{EBd} \quad (39)$$

where \mathbf{B} is the strain-nodal displacement matrix and \mathbf{d} is the nodal displacement vector which is known for each element once the global FE equation has been solved.

Stresses can be evaluated at any point inside the element (such as the center) or at the nodes. Contour plots are usually used in FEA software packages (during post-process) for users to visually inspect the stress results.

The von Mises Stress:

The von Mises stress is the *effective* or *equivalent* stress for 2-D and 3-D stress analysis. For a ductile material, the stress level is considered to be safe, if

$$\sigma_e \leq \sigma_Y$$

where σ_e is the von Mises stress and σ_Y the yield stress of the material. This is a generalization of the 1-D (experimental) result to 2-D and 3-D situations.

The von Mises stress is defined by

$$\sigma_e = \frac{1}{\sqrt{2}} \sqrt{(\sigma_1 - \sigma_2)^2 + (\sigma_2 - \sigma_3)^2 + (\sigma_3 - \sigma_1)^2} \quad (40)$$

in which σ_1, σ_2 and σ_3 are the three principle stresses at the considered point in a structure.

For 2-D problems, the two principle stresses in the plane are determined by

$$\begin{aligned} \sigma_1^P &= \frac{\sigma_x + \sigma_y}{2} + \sqrt{\left(\frac{\sigma_x - \sigma_y}{2}\right)^2 + \tau_{xy}^2} \\ \sigma_2^P &= \frac{\sigma_x + \sigma_y}{2} - \sqrt{\left(\frac{\sigma_x - \sigma_y}{2}\right)^2 + \tau_{xy}^2} \end{aligned} \quad (41)$$

Thus, we can also express the von Mises stress in terms of the stress components in the xy coordinate system. For plane stress conditions, we have,

$$\sigma_e = \sqrt{(\sigma_x + \sigma_y)^2 - 3(\sigma_x \sigma_y - \tau_{xy}^2)} \quad (42)$$

Averaged Stresses:

Stresses are usually averaged at nodes in FEA software packages to provide more accurate stress values. This option should be turned off at nodes between two materials or other geometry discontinuity locations where stress discontinuity does exist.

Discussions

1) Know the behaviors of each type of elements:

$T3$ and $Q4$: linear displacement, constant strain and stress;

$T6$ and $Q8$: quadratic displacement, linear strain and stress.

2) Choose the right type of elements for a given problem:

When in doubt, use higher order elements or a finer mesh.

3) Avoid elements with large aspect ratios and corner angles:

$$\text{Aspect ratio} = L_{max} / L_{min}$$

where L_{max} and L_{min} are the largest and smallest characteristic lengths of an element, respectively.

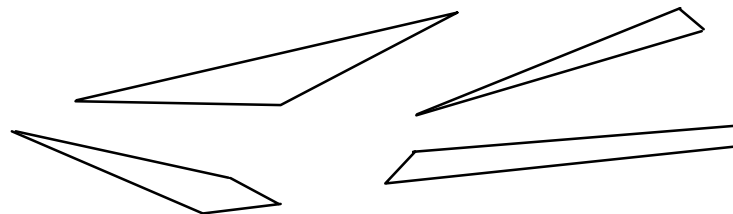

Elements with Bad Shapes

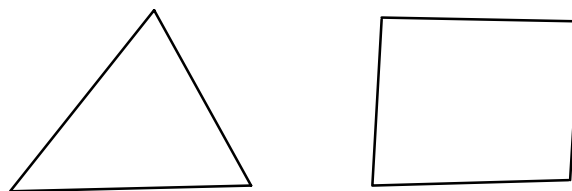

Elements with Nice Shapes

4) *Connect the elements properly:*

Don't leave unintended gaps or free elements in FE models.

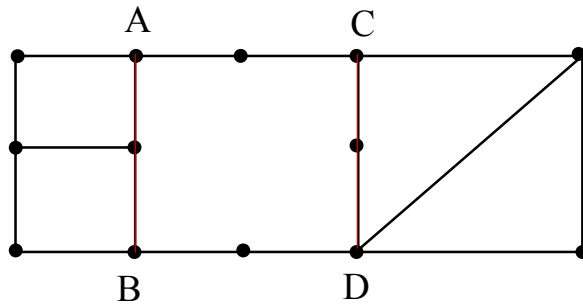

Improper connections (gaps along AB and CD)

Chapter 4. Finite Element Modeling and Solution Techniques

I. Symmetry

A structure possesses *symmetry* if its components are arranged in a periodic or reflective manner.

Types of Symmetry:

- Reflective (mirror, bilateral) symmetry
- Rotational (cyclic) symmetry
- Axisymmetry
- Translational symmetry
- ...

Examples:

...

Applications of the symmetry properties:

- Reducing the size of the problems (save CPU time, disk space, postprocessing effort, etc.)
- Simplifying the modeling task
- Checking the FEA results
- ...

Symmetry of a structure should be fully exploited and retained in the FE model to ensure the efficiency and quality of FE solutions.

Examples:

...

Cautions:

In vibration and buckling analyses, symmetry concepts, in general, should not be used in FE solutions (works fine in modeling), since symmetric structures often have antisymmetric vibration or buckling modes.

II. Substructures (Superelements)

Substructuring is a process of analyzing a large structure as a collection of (natural) components. The FE models for these components are called *substructures* or *superelements* (SE).

Physical Meaning:

A finite element model of a portion of structure.

Mathematical Meaning:

Boundary matrices which are load and stiffness matrices reduced (condensed) from the *interior* points to the *exterior* or boundary points.

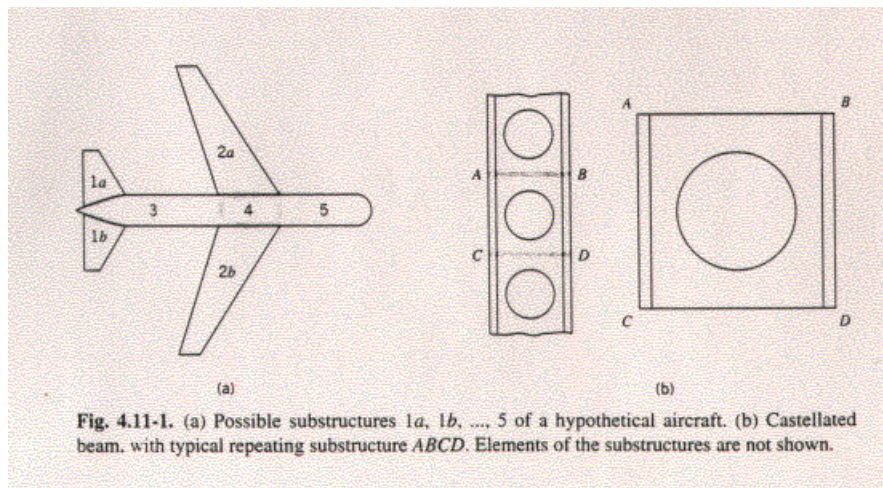

Advantages of Using Substructures/Superelements:

- Large problems (which will otherwise exceed your computer capabilities)
- Less CPU time per run once the superelements have been processed (i.e., matrices have been saved)
- Components may be modeled by different groups
- Partial redesign requires only partial reanalysis (reduced cost)
- Efficient for problems with local nonlinearities (such as confined plastic deformations) which can be placed in one superelement (residual structure)
- Exact for static stress analysis

Disadvantages:

- Increased overhead for file management
- Matrix condensation for dynamic problems introduce new approximations
- ...

III. Equation Solving

Direct Methods (Gauss Elimination):

- Solution time proportional to NB^2 (N is the dimension of the matrix, B the bandwidth)
- Suitable for small to medium problems, or slender structures (small bandwidth)
- Easy to handle multiple load cases

Iterative Methods:

- Solution time is unknown beforehand
- Reduced storage requirement
- Suitable for large problems, or bulky structures (large bandwidth, converge faster)
- Need solving again for different load cases

Gauss Elimination - Example:

$$\begin{bmatrix} 8 & -2 & 0 \\ -2 & 4 & -3 \\ 0 & -3 & 3 \end{bmatrix} \begin{Bmatrix} x_1 \\ x_2 \\ x_3 \end{Bmatrix} = \begin{Bmatrix} 2 \\ -1 \\ 3 \end{Bmatrix} \quad \text{or} \quad \mathbf{Ax} = \mathbf{b}.$$

Forward Elimination:

$$\text{Form} \quad \begin{array}{l} (1) \\ (2) \\ (3) \end{array} \begin{bmatrix} 8 & -2 & 0 & | & 2 \\ -2 & 4 & -3 & | & -1 \\ 0 & -3 & 3 & | & 3 \end{bmatrix};$$

(1) + 4 x (2) \Rightarrow (2):

$$\begin{array}{l} (1) \\ (2) \\ (3) \end{array} \begin{bmatrix} 8 & -2 & 0 & | & 2 \\ 0 & 14 & -12 & | & -2 \\ 0 & -3 & 3 & | & 3 \end{bmatrix};$$

(2) + $\frac{14}{3}$ (3) \Rightarrow (3):

$$\begin{array}{l} (1) \\ (2) \\ (3) \end{array} \begin{bmatrix} 8 & -2 & 0 & | & 2 \\ 0 & 14 & -12 & | & -2 \\ 0 & 0 & 2 & | & 12 \end{bmatrix};$$

Back Substitution:

$$\begin{array}{l} x_3 = 12/2 = 6 \\ x_2 = (-2 + 12x_3)/14 = 5 \\ x_1 = (2 + 2x_2)/8 = 1.5 \end{array} \quad \text{or} \quad \mathbf{x} = \begin{Bmatrix} 1.5 \\ 5 \\ 6 \end{Bmatrix}.$$

Iterative Method - Example:

The Gauss-Seidel Method

$$\mathbf{Ax} = \mathbf{b} \quad (\mathbf{A} \text{ is symmetric})$$

$$\text{or} \quad \sum_{j=1}^N a_{ij} x_j = b_i, \quad i = 1, 2, \dots, N.$$

Start with an estimate $\mathbf{x}^{(0)}$ and then iterate using the following:

$$x_i^{(k+1)} = \frac{1}{a_{ii}} \left[b_i - \sum_{j=1}^{i-1} a_{ij} x_j^{(k+1)} - \sum_{j=i+1}^N a_{ij} x_j^{(k)} \right],$$

for $i = 1, 2, \dots, N$.

In vector form,

$$\mathbf{x}^{(k+1)} = \mathbf{A}_D^{-1} \left[\mathbf{b} - \mathbf{A}_L \mathbf{x}^{(k+1)} - \mathbf{A}_L^T \mathbf{x}^{(k)} \right],$$

where

$\mathbf{A}_D = \langle a_{ii} \rangle$ is the diagonal matrix of \mathbf{A} ,

\mathbf{A}_L is the lower triangular matrix of \mathbf{A} ,

such that $\mathbf{A} = \mathbf{A}_D + \mathbf{A}_L + \mathbf{A}_L^T$.

Iterations continue until solution \mathbf{x} converges, i.e.

$$\frac{\|\mathbf{x}^{(k+1)} - \mathbf{x}^{(k)}\|}{\|\mathbf{x}^{(k)}\|} \leq \varepsilon,$$

where ε is the tolerance for convergence control.

IV. Nature of Finite Element Solutions

- FE Model – A mathematical model of the real structure, based on many approximations.
- Real Structure -- Infinite number of nodes (physical points or particles), thus infinite number of DOF's.
- FE Model – finite number of nodes, thus finite number of DOF's.

⇒ Displacement field is controlled (or constrained) by the values at a limited number of nodes.

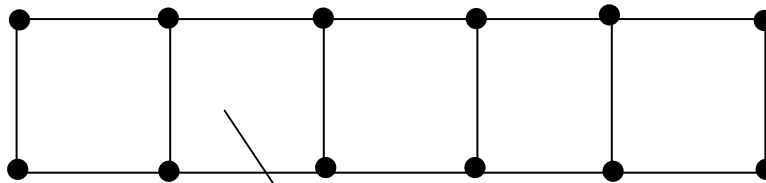

Recall that on an element :

$$u = \sum_{\alpha=1}^4 N_{\alpha} u_{\alpha}$$

Stiffening Effect:

- FE Model is stiffer than the real structure.
- In general, displacement results are smaller in magnitudes than the exact values.

Hence, FEM solution of displacement provides a *lower bound* of the exact solution.

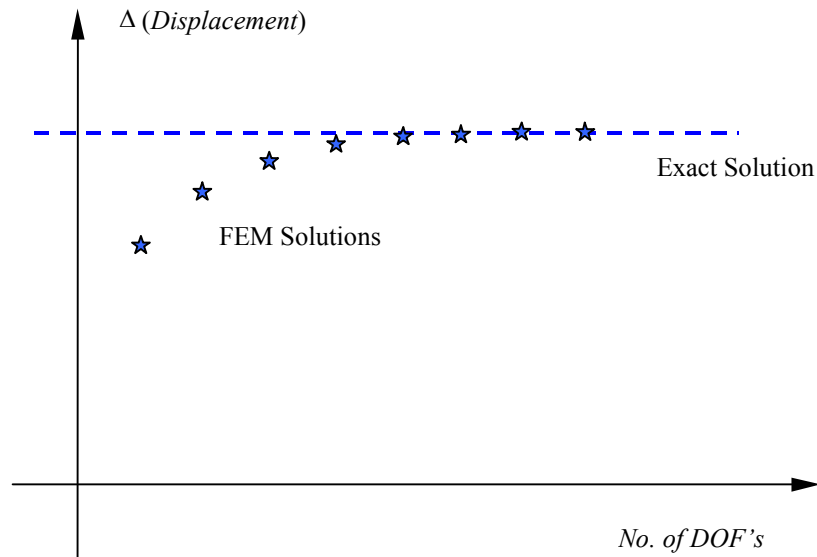

The FEM solution approaches the exact solution from below.

This is true for displacement based FEA!

V. Numerical Error

Error \neq Mistakes in FEM (modeling or solution).

Type of Errors:

- Modeling Error (beam, plate ... theories)
- Discretization Error (finite, piecewise ...)
- Numerical Error (in solving FE equations)

Example (numerical error):

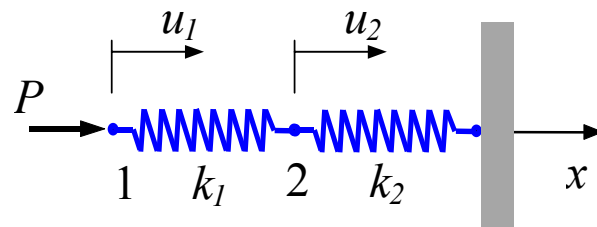

FE Equations:

$$\begin{bmatrix} k_1 & -k_1 \\ -k_1 & k_1 + k_2 \end{bmatrix} \begin{Bmatrix} u_1 \\ u_2 \end{Bmatrix} = \begin{Bmatrix} P \\ 0 \end{Bmatrix}$$

and $Det \mathbf{K} = k_1 k_2$.

The system will be *singular* if k_2 is small compared with k_1 .

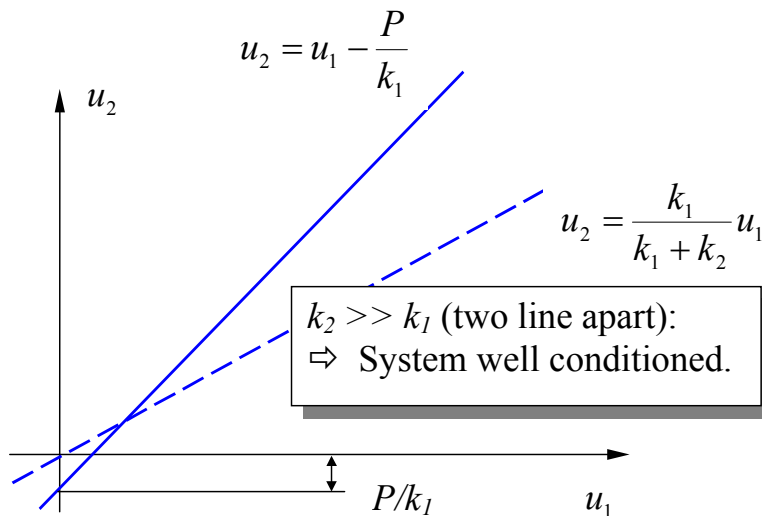
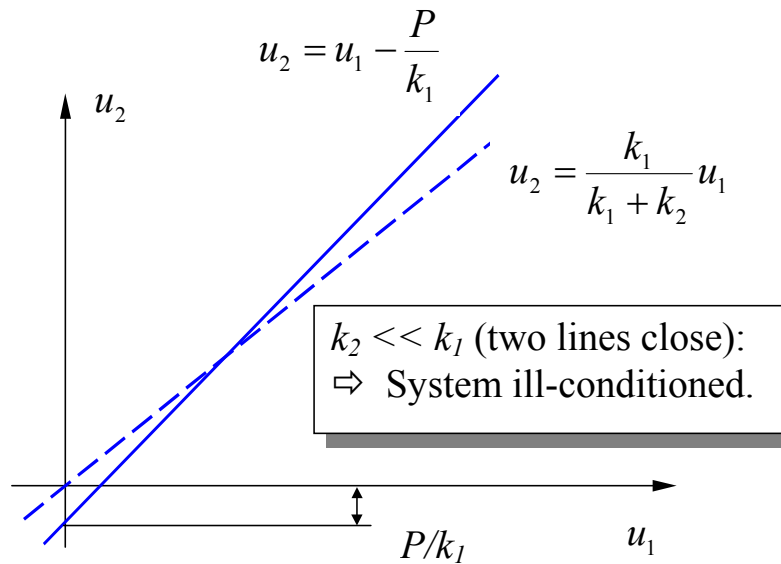

- Large difference in stiffness of different parts in FE model may cause ill-conditioning in FE equations. Hence giving results with large errors.
- Ill-conditioned system of equations can lead to large changes in solution with small changes in input (right hand side vector).

VI. Convergence of FE Solutions

As the mesh in an FE model is “refined” repeatedly, the FE solution will converge to the exact solution of the mathematical model of the problem (the model based on bar, beam, plane stress/strain, plate, shell, or 3-D elasticity theories or assumptions).

Type of Refinements:

h-refinement: reduce the size of the element (“ h ” refers to the typical size of the elements);

p-refinement: Increase the order of the polynomials on an element (linear to quadratic, etc.; “ h ” refers to the highest order in a polynomial);

r-refinement: re-arrange the nodes in the mesh;

hp-refinement: Combination of the h - and p -refinements (better results!).

Examples:

...

VII. Adaptivity (h-, p-, and hp-Methods)

- Future of FE applications
- Automatic refinement of FE meshes until converged results are obtained
- User's responsibility reduced: only need to generate a good initial mesh

Error Indicators:

Define,

σ --- element by element stress field (discontinuous),

σ^* --- averaged or smooth stress (continuous),

$\sigma_E = \sigma - \sigma^*$ --- the error stress field.

Compute strain energy,

$$U = \sum_{i=1}^M U_i, \quad U_i = \int_{V_i} \frac{1}{2} \boldsymbol{\sigma}^T \mathbf{E}^{-1} \boldsymbol{\sigma} dV;$$

$$U^* = \sum_{i=1}^M U_i^*, \quad U_i^* = \int_{V_i} \frac{1}{2} \boldsymbol{\sigma}^{*T} \mathbf{E}^{-1} \boldsymbol{\sigma}^* dV;$$

$$U_E = \sum_{i=1}^M U_{Ei}, \quad U_{Ei} = \int_{V_i} \frac{1}{2} \boldsymbol{\sigma}_E^T \mathbf{E}^{-1} \boldsymbol{\sigma}_E dV;$$

where M is the total number of elements, V_i is the volume of the element i .

One error indicator --- the relative energy error:

$$\eta = \left[\frac{U_E}{U + U_E} \right]^{1/2}. \quad (0 \leq \eta \leq 1)$$

The indicator η is computed after each FE solution. Refinement of the FE model continues until, say

$$\eta \leq 0.05.$$

=> converged FE solution.

Examples:

...

Chapter 5. Plate and Shell Elements

I. Plate Theory

- Flat plate
- Lateral loading
- Bending behavior dominates

Note the following similarity:

1-D straight beam model \Leftrightarrow *2-D flat plate model*

Applications:

- Shear walls
- Floor panels
- Shelves
- ...

Forces and Moments Acting on the Plate:

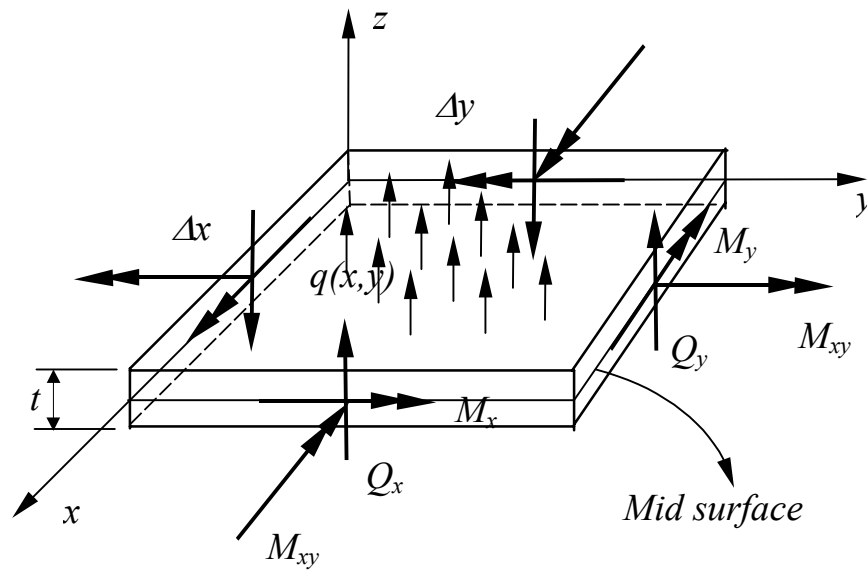

Stresses:

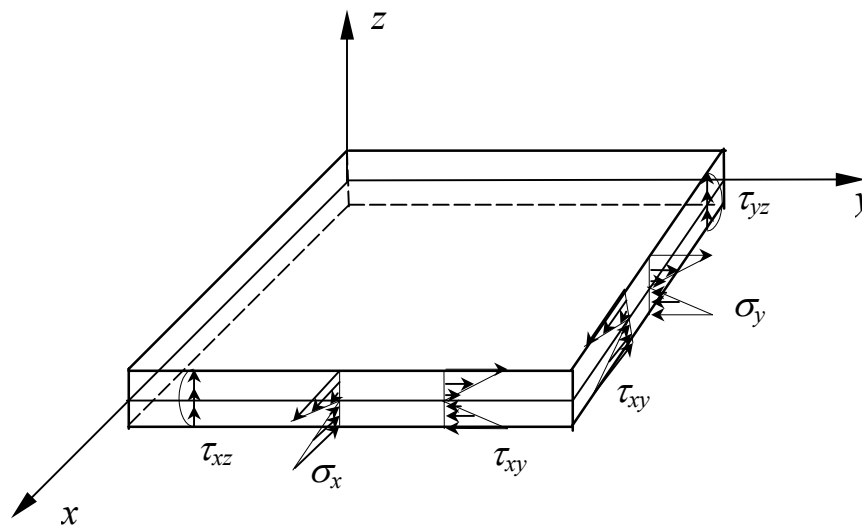

Relations Between Forces and Stresses

Bending moments (per unit length):

$$M_x = \int_{-t/2}^{t/2} \sigma_x z dz, \quad (N \cdot m / m) \quad (1)$$

$$M_y = \int_{-t/2}^{t/2} \sigma_y z dz, \quad (N \cdot m / m) \quad (2)$$

Twisting moment (per unit length):

$$M_{xy} = \int_{-t/2}^{t/2} \tau_{xy} z dz, \quad (N \cdot m / m) \quad (3)$$

Shear Forces (per unit length):

$$Q_x = \int_{-t/2}^{t/2} \tau_{xz} dz, \quad (N / m) \quad (4)$$

$$Q_y = \int_{-t/2}^{t/2} \tau_{yz} dz, \quad (N / m) \quad (5)$$

Maximum bending stresses:

$$(\sigma_x)_{\max} = \pm \frac{6M_x}{t^2}, \quad (\sigma_y)_{\max} = \pm \frac{6M_y}{t^2}. \quad (6)$$

- Maximum stress is always at $z = \pm t/2$
- No bending stresses at midsurface (similar to the beam model)

Thin Plate Theory (Kirchhoff Plate Theory)

Assumptions (similar to those in the beam theory):

A straight line along the normal to the mid surface remains straight and normal to the deflected mid surface after loading, that is, there is no transverse shear deformation:

$$\gamma_{xz} = \gamma_{yz} = 0.$$

Displacement:

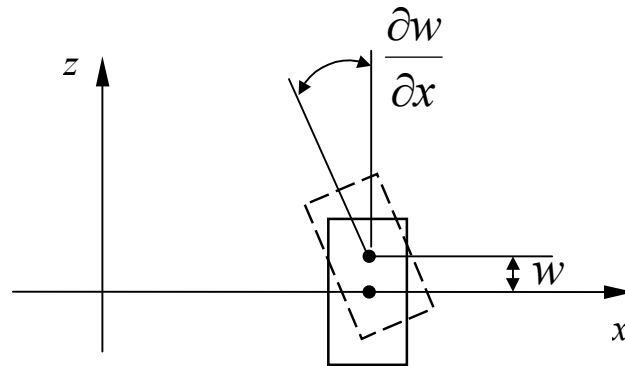

$$w = w(x, y), \quad (\text{deflection})$$

$$u = -z \frac{\partial w}{\partial x}, \quad (7)$$

$$v = -z \frac{\partial w}{\partial y}.$$

Strains:

$$\begin{aligned}\varepsilon_x &= -z \frac{\partial^2 w}{\partial x^2}, \\ \varepsilon_y &= -z \frac{\partial^2 w}{\partial y^2}, \\ \gamma_{xy} &= -2z \frac{\partial^2 w}{\partial x \partial y}.\end{aligned}\tag{8}$$

Note that there is no stretch of the mid surface due to the deflection (bending) of the plate.

Stresses (plane stress state):

$$\begin{Bmatrix} \sigma_x \\ \sigma_y \\ \tau_{xy} \end{Bmatrix} = \frac{E}{1-\nu^2} \begin{bmatrix} 1 & \nu & 0 \\ \nu & 1 & 0 \\ 0 & 0 & (1-\nu)/2 \end{bmatrix} \begin{Bmatrix} \varepsilon_x \\ \varepsilon_y \\ \gamma_{xy} \end{Bmatrix},$$

or,

$$\begin{Bmatrix} \sigma_x \\ \sigma_y \\ \tau_{xy} \end{Bmatrix} = -z \frac{E}{1-\nu^2} \begin{bmatrix} 1 & \nu & 0 \\ \nu & 1 & 0 \\ 0 & 0 & (1-\nu) \end{bmatrix} \begin{Bmatrix} \frac{\partial^2 w}{\partial x^2} \\ \frac{\partial^2 w}{\partial y^2} \\ \frac{\partial^2 w}{\partial x \partial y} \end{Bmatrix}.\tag{9}$$

Main variable: deflection $w = w(x, y)$.

Governing Equation:

$$D\nabla^4 w = q(x, y), \quad (10)$$

where

$$\nabla^4 \equiv \left(\frac{\partial^4}{\partial x^4} + 2 \frac{\partial^4}{\partial x^2 \partial y^2} + \frac{\partial^4}{\partial y^4} \right),$$

$$D = \frac{Et^3}{12(1-\nu^2)} \quad (\text{the bending rigidity of the plate}),$$

q = lateral distributed load (force/area).

Compare the 1-D equation for straight beam:

$$EI \frac{d^4 w}{dx^4} = q(x).$$

Note: Equation (10) represents the equilibrium condition in the z -direction. To see this, refer to the previous figure showing all the forces on a plate element. Summing the forces in the z -direction, we have,

$$Q_x \Delta y + Q_y \Delta x + q \Delta x \Delta y = 0,$$

which yields,

$$\frac{\partial Q_x}{\partial x} + \frac{\partial Q_y}{\partial y} + q(x, y) = 0.$$

Substituting the following relations into the above equation, we obtain Eq. (10).

Shear forces and bending moments:

$$Q_x = \frac{\partial M_x}{\partial x} + \frac{\partial M_{xy}}{\partial y}, \quad Q_y = \frac{\partial M_{xy}}{\partial x} + \frac{\partial M_y}{\partial y},$$

$$M_x = D \left(\frac{\partial^2 w}{\partial x^2} + \nu \frac{\partial^2 w}{\partial y^2} \right), \quad M_y = D \left(\frac{\partial^2 w}{\partial y^2} + \nu \frac{\partial^2 w}{\partial x^2} \right).$$

The fourth-order partial differential equation, given in (10) and in terms of the deflection $w(x,y)$, needs to be solved under certain given boundary conditions.

Boundary Conditions:

$$\text{Clamped:} \quad w = 0, \quad \frac{\partial w}{\partial n} = 0; \quad (11)$$

$$\text{Simply supported:} \quad w = 0, \quad M_n = 0; \quad (12)$$

$$\text{Free:} \quad Q_n = 0, \quad M_n = 0; \quad (13)$$

where n is the normal direction of the boundary. Note that the given values in the boundary conditions shown above can be non-zero values as well.

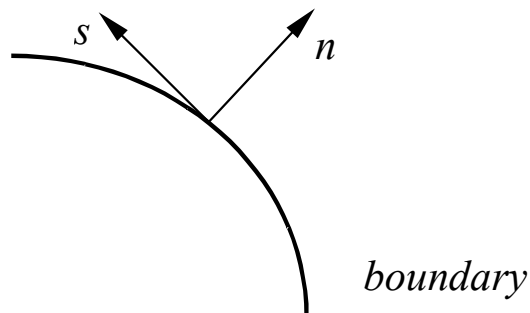

Examples:

A square plate with four edges clamped or hinged, and under a uniform load q or a concentrated force P at the center C .

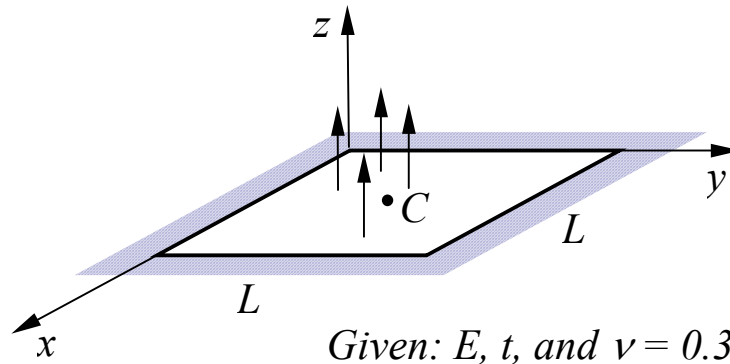

For this simple geometry, Eq. (10) with boundary condition (11) or (12) can be solved analytically. The maximum deflections are given in the following table for the different cases.

Deflection at the Center (w_c)

	<i>Clamped</i>	<i>Simply supported</i>
Under uniform load q	$0.00126 qL^4/D$	$0.00406 qL^4/D$
Under concentrated force P	$0.00560 PL^2/D$	$0.0116 PL^2/D$

in which: $D = Et^3/(12(1-\nu^2))$.

These values can be used to verify the FEA solutions.

Thick Plate Theory (Mindlin Plate Theory)

If the thickness t of a plate is not “thin”, e.g., $t/L \geq 1/10$ ($L =$ a characteristic dimension of the plate), then the thick plate theory by Mindlin should be applied. This theory accounts for the angle changes within a cross section, that is,

$$\gamma_{xz} \neq 0, \quad \gamma_{yz} \neq 0.$$

This means that a line which is normal to the mid surface before the deformation will not be so after the deformation.

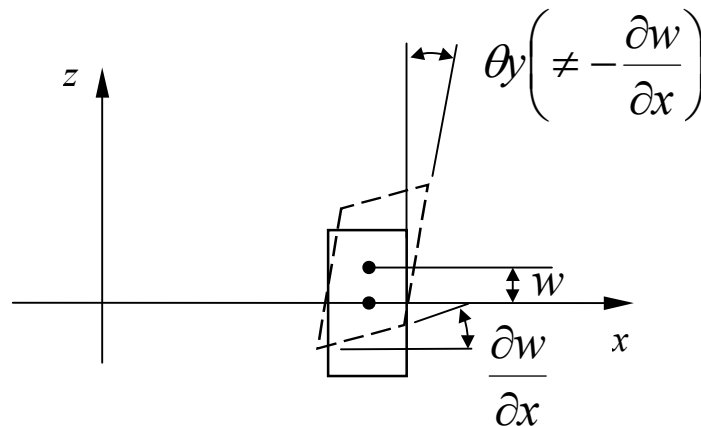

New independent variables:

θ_x and θ_y : rotation angles of a line, which is normal to the mid surface before the deformation, about x - and y -axis, respectively.

New relations:

$$u = z\theta_y, \quad v = -z\theta_x; \quad (14)$$

$$\varepsilon_x = z \frac{\partial \theta_y}{\partial x},$$

$$\varepsilon_y = -z \frac{\partial \theta_x}{\partial y},$$

$$\gamma_{xy} = z \left(\frac{\partial \theta_y}{\partial y} - \frac{\partial \theta_x}{\partial x} \right), \quad (15)$$

$$\gamma_{xz} = \frac{\partial w}{\partial x} + \theta_y,$$

$$\gamma_{yz} = \frac{\partial w}{\partial y} - \theta_x.$$

Note that if we imposed the conditions (or assumptions) that

$$\gamma_{xz} = \frac{\partial w}{\partial x} + \theta_y = 0, \quad \gamma_{yz} = \frac{\partial w}{\partial y} - \theta_x = 0,$$

then we can recover the relations applied in the thin plate theory.

Main variables: $w(x, y)$, $\theta_x(x, y)$ and $\theta_y(x, y)$.

The governing equations and boundary conditions can be established for thick plate based on the above assumptions.

II. Plate Elements

Kirchhoff Plate Elements:

4-Node Quadrilateral Element

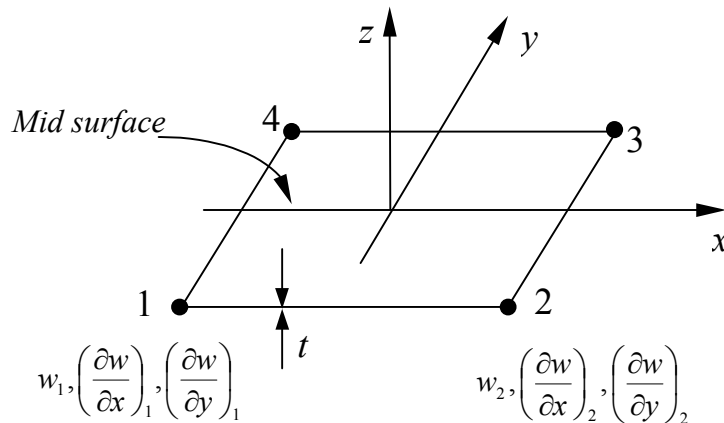

DOF at each node: $w, \frac{\partial w}{\partial x}, \frac{\partial w}{\partial y}$.

On each element, the deflection $w(x,y)$ is represented by

$$w(x, y) = \sum_{i=1}^4 \left[N_i w_i + N_{xi} \left(\frac{\partial w}{\partial x} \right)_i + N_{yi} \left(\frac{\partial w}{\partial y} \right)_i \right],$$

where N_i , N_{xi} and N_{yi} are shape functions. This is an incompatible element! The stiffness matrix is still of the form

$$\mathbf{k} = \int_V \mathbf{B}^T \mathbf{E} \mathbf{B} dV,$$

where \mathbf{B} is the strain-displacement matrix, and \mathbf{E} the stress-strain matrix.

Mindlin Plate Elements:

4-Node Quadrilateral

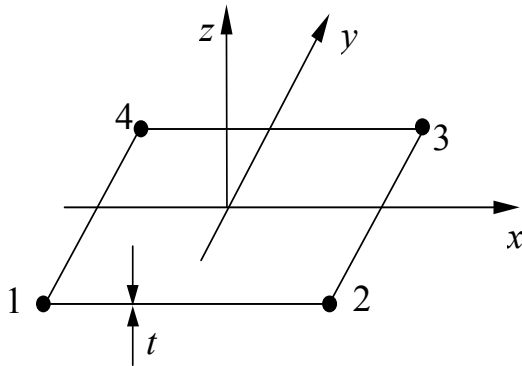

8-Node Quadrilateral

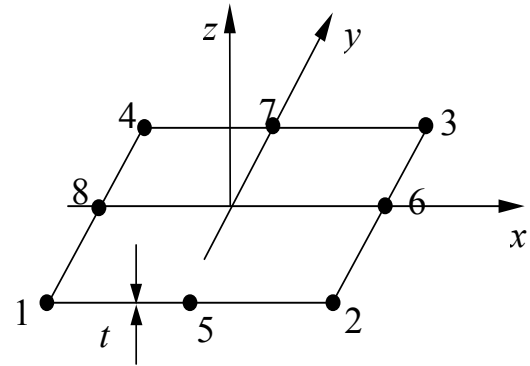

DOF at each node: w , θ_x and θ_y .

On each element:

$$w(x, y) = \sum_{i=1}^n N_i w_i,$$

$$\theta_x(x, y) = \sum_{i=1}^n N_i \theta_{xi},$$

$$\theta_y(x, y) = \sum_{i=1}^n N_i \theta_{yi}.$$

- Three independent fields.
- Deflection $w(x, y)$ is linear for Q4, and quadratic for Q8.

Discrete Kirchhoff Element:

Triangular plate element (not available in *ANSYS*).

Start with a 6-node triangular element,

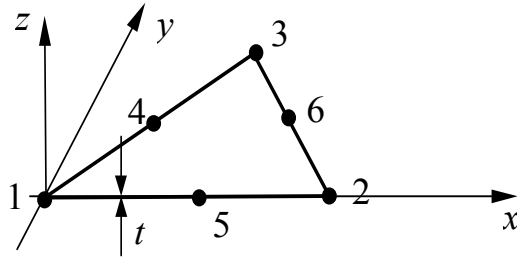

DOF at corner nodes: $w, \frac{\partial w}{\partial x}, \frac{\partial w}{\partial y}, \theta_x, \theta_y$;

DOF at mid side nodes: θ_x, θ_y .

Total DOF = 21.

Then, impose conditions $\gamma_{xz} = \gamma_{yz} = 0$, etc., at selected nodes to reduce the DOF (using relations in (15)). Obtain:

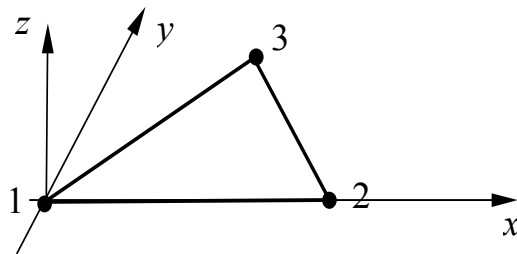

At each node: $w, \theta_x \left(= \frac{\partial w}{\partial x} \right), \theta_y \left(= \frac{\partial w}{\partial y} \right)$.

Total DOF = 9 (DKT Element).

- Incompatible $w(x,y)$; convergence is faster (w is cubic along each edge) and it is efficient.

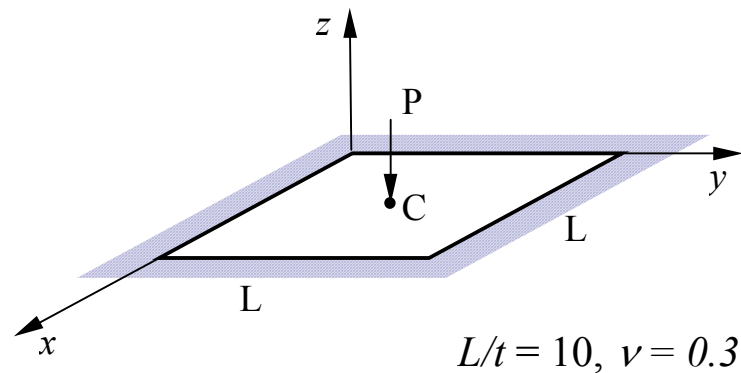
Test Problem:

ANSYS 4-node quadrilateral plate element.

ANSYS Result for w_c

Mesh	$w_c (\times PL^2/D)$
2×2	0.00593
4×4	0.00598
8×8	0.00574
16×16	0.00565
⋮	⋮
<i>Exact Solution</i>	0.00560

Question: Converges from “above”? Contradiction to what we learnt about the nature of the FEA solution?

Reason: This is an incompatible element (See comments on p. 177).

III. Shells and Shell Elements

Shells – Thin structures which span over curved surfaces.

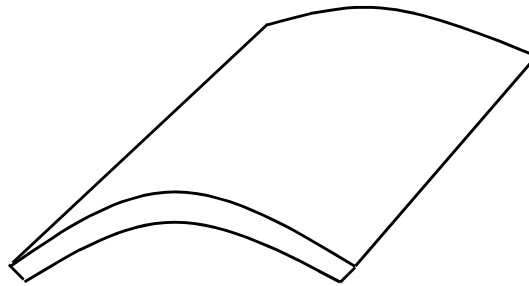

Example:

- Sea shell, egg shell (the wonder of the nature);
- Containers, pipes, tanks;
- Car bodies;
- Roofs, buildings (the Superdome), etc.

Forces in shells:

Membrane forces + Bending Moments

(cf. plates: bending only)

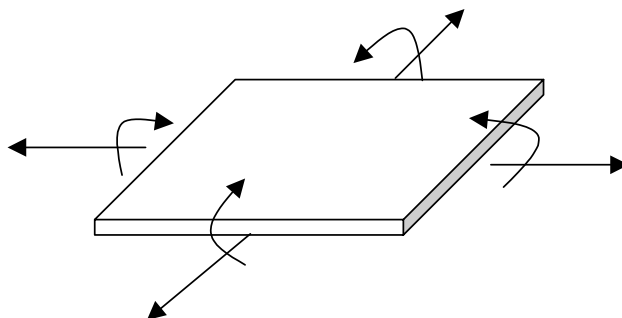

Example: A Cylindrical Container.

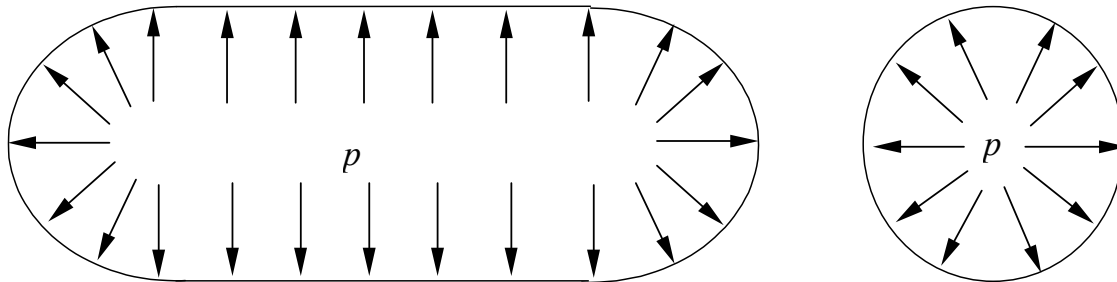

internal forces:

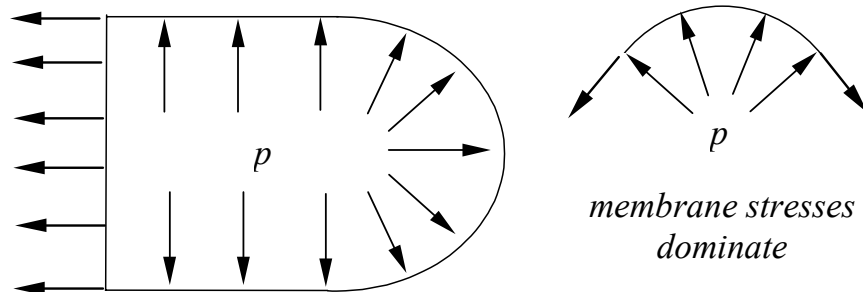

Shell Theory:

- Thin shell theory
- Thick shell theory

Shell theories are the most complicated ones to formulate and analyze in mechanics (Russian's contributions).

- Engineering \neq Craftsmanship
- Demand strong analytical skill

Shell Elements:

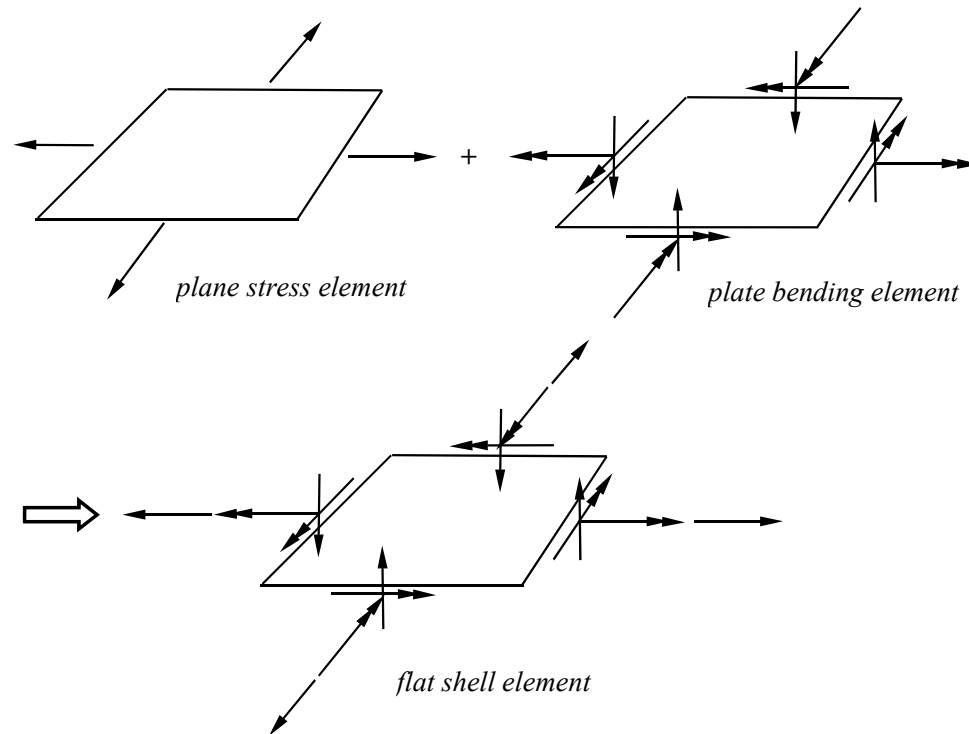

cf.: bar + simple beam element \Rightarrow general beam element.

DOF at each node:

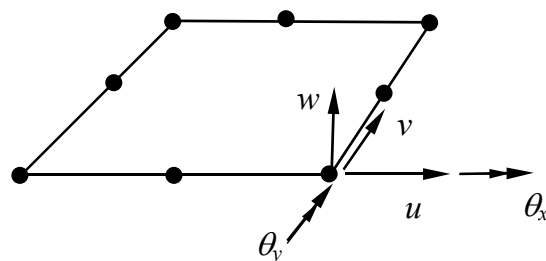

Q4 or Q8 shell element.

Curved shell elements:

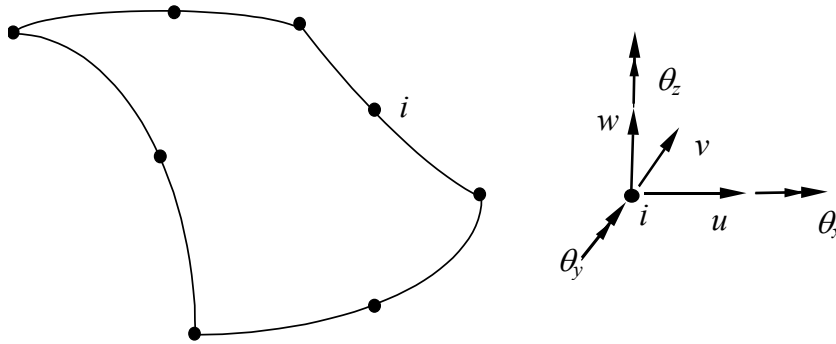

- Based on shell theories;
- Most general shell elements (flat shell and plate elements are subsets);
- Complicated in formulation.

ANSYS ANALYSIS (1000 PSI INFLUENCE PRESSURE)

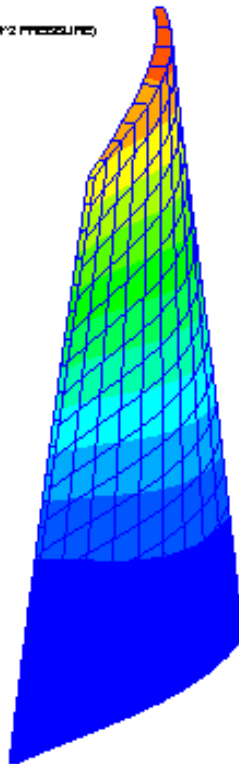

Test Cases:

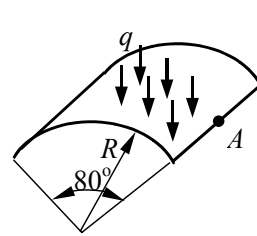

Roof

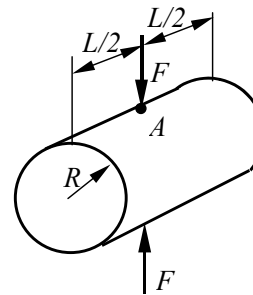

Pinched Cylinder

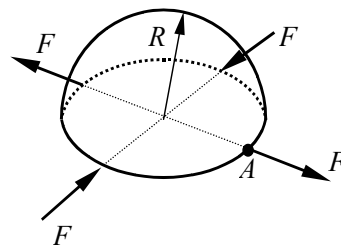

Pinched Hemisphere

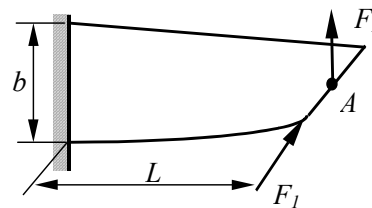

Twisted Strip (90°)

⇒ Check the Table, on page 188 of Cook's book, for values of the displacement Δ_A under the various loading conditions.

Difficulties in Application:

- Non uniform thickness (turbo blades, vessels with stiffeners, thin layered structures, etc.);
- Should turn to 3-D theory and apply solid elements.

Chapter 6. Solid Elements for 3-D Problems

I. 3-D Elasticity Theory

Stress State:

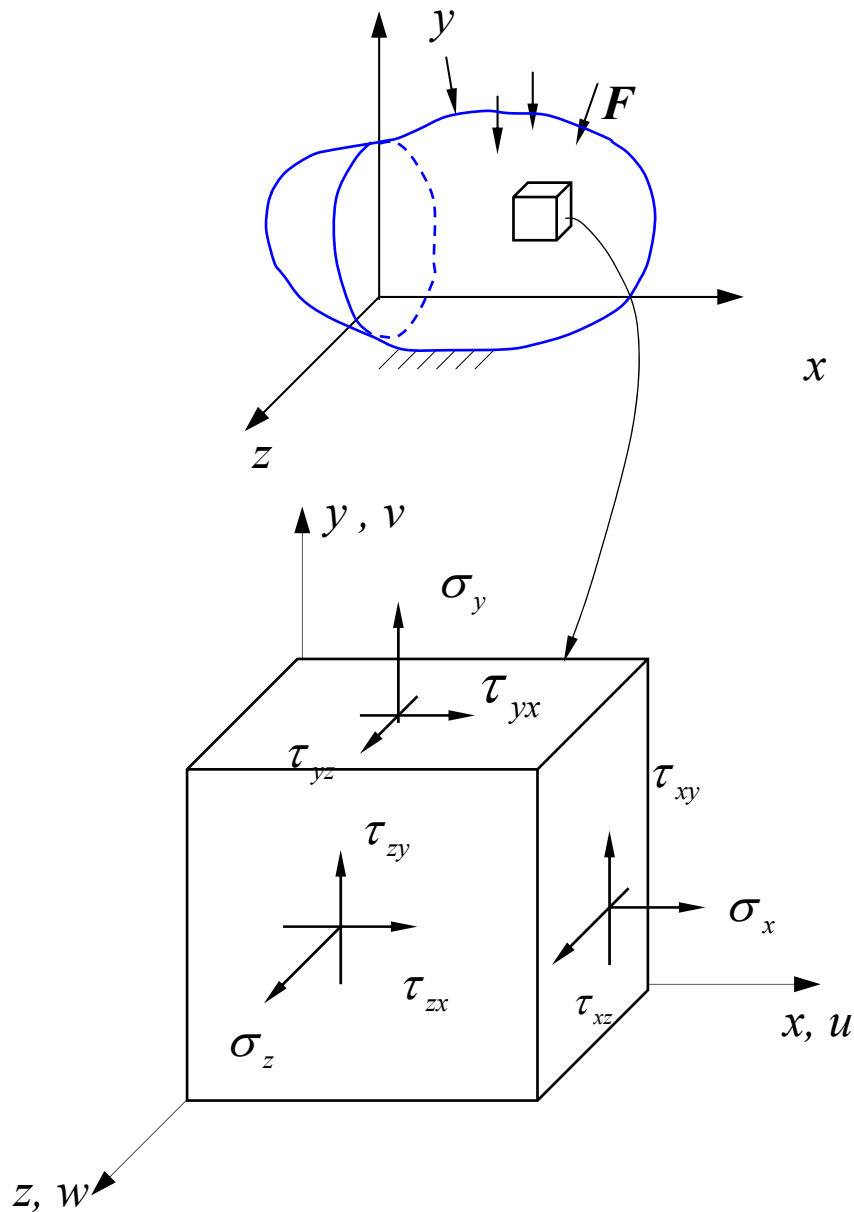

$$\boldsymbol{\sigma} = \{ \boldsymbol{\sigma} \} = \begin{Bmatrix} \sigma_x \\ \sigma_y \\ \sigma_z \\ \tau_{xy} \\ \tau_{yz} \\ \tau_{zx} \end{Bmatrix}, \quad \text{or} \quad [\sigma_{ij}] \quad (1)$$

Strains:

$$\boldsymbol{\varepsilon} = \{ \boldsymbol{\varepsilon} \} = \begin{Bmatrix} \varepsilon_x \\ \varepsilon_y \\ \varepsilon_z \\ \gamma_{xy} \\ \gamma_{yz} \\ \gamma_{zx} \end{Bmatrix}, \quad \text{or} \quad [\varepsilon_{ij}] \quad (2)$$

Stress-strain relation:

$$\begin{Bmatrix} \sigma_x \\ \sigma_y \\ \sigma_z \\ \tau_{xy} \\ \tau_{yz} \\ \tau_{zx} \end{Bmatrix} = \frac{E}{(1+\nu)(1-2\nu)} \begin{bmatrix} 1-\nu & \nu & \nu & 0 & 0 & 0 \\ \nu & 1-\nu & \nu & 0 & 0 & 0 \\ \nu & \nu & 1-\nu & 0 & 0 & 0 \\ 0 & 0 & 0 & \frac{1-2\nu}{2} & 0 & 0 \\ 0 & 0 & 0 & 0 & \frac{1-2\nu}{2} & 0 \\ 0 & 0 & 0 & 0 & 0 & \frac{1-2\nu}{2} \end{bmatrix} \begin{Bmatrix} \varepsilon_x \\ \varepsilon_y \\ \varepsilon_z \\ \gamma_{xy} \\ \gamma_{yz} \\ \gamma_{zx} \end{Bmatrix}$$

$$\text{or} \quad \boldsymbol{\sigma} = \mathbf{E}\boldsymbol{\varepsilon} \quad (3)$$

Displacement:

$$\mathbf{u} = \begin{Bmatrix} u(x, y, z) \\ v(x, y, z) \\ w(x, y, z) \end{Bmatrix} = \begin{Bmatrix} u_1 \\ u_2 \\ u_3 \end{Bmatrix} \quad (4)$$

Strain-Displacement Relation:

$$\begin{aligned} \varepsilon_x &= \frac{\partial u}{\partial x}, \quad \varepsilon_y = \frac{\partial v}{\partial y}, \quad \varepsilon_z = \frac{\partial w}{\partial z}, \\ \gamma_{xy} &= \frac{\partial v}{\partial x} + \frac{\partial u}{\partial y}, \quad \gamma_{yz} = \frac{\partial w}{\partial y} + \frac{\partial v}{\partial z}, \quad \gamma_{xz} = \frac{\partial u}{\partial z} + \frac{\partial w}{\partial x} \end{aligned} \quad (5)$$

or

$$\varepsilon_{ij} = \frac{1}{2} \left(\frac{\partial u_i}{\partial x_j} + \frac{\partial u_j}{\partial x_i} \right), \quad (i, j = 1, 2, 3)$$

or simply,

$$\varepsilon_{ij} = \frac{1}{2} (u_{i,j} + u_{j,i}) \quad (\text{tensor notation})$$

Equilibrium Equations:

$$\begin{aligned} \frac{\partial \sigma_x}{\partial x} + \frac{\partial \tau_{xy}}{\partial y} + \frac{\partial \tau_{xz}}{\partial z} + f_x &= 0, \\ \frac{\partial \tau_{yx}}{\partial x} + \frac{\partial \sigma_y}{\partial y} + \frac{\partial \tau_{yz}}{\partial z} + f_y &= 0, \\ \frac{\partial \tau_{zx}}{\partial x} + \frac{\partial \tau_{zy}}{\partial y} + \frac{\partial \sigma_z}{\partial z} + f_z &= 0, \end{aligned} \quad (6)$$

or

$$\sigma_{ij,j} + f_i = 0$$

Boundary Conditions (BC's):

$$\begin{aligned} u_i &= \bar{u}_i, & \text{on } \Gamma_u & \text{(specified displacement)} \\ t_i &= \bar{t}_i, & \text{on } \Gamma_\sigma & \text{(specified traction)} \end{aligned} \quad (7)$$

(traction $t_i = \sigma_{ij} n_j$)

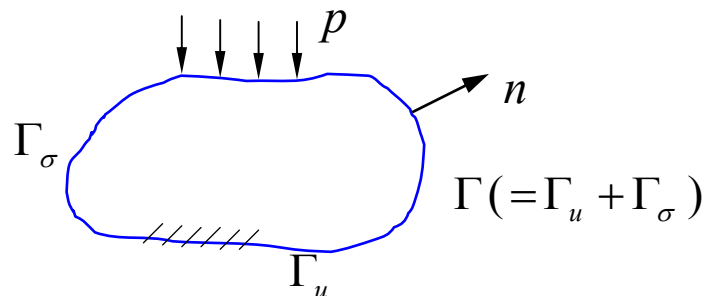
**Stress Analysis:**

Solving equations in (3), (5) and (6) under the BC's in (7) provides the stress, strain and displacement fields (15 equations for 15 unknowns for 3-D problems). Analytical solutions are difficult to find!

II. Finite Element Formulation

Displacement Field:

$$\begin{aligned}
 u &= \sum_{i=1}^N N_i u_i \\
 v &= \sum_{i=1}^N N_i v_i \\
 w &= \sum_{i=1}^N N_i w_i
 \end{aligned} \tag{8}$$

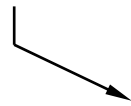

Nodal values

In matrix form:

$$\begin{Bmatrix} u \\ v \\ w \end{Bmatrix}_{(3 \times 1)} = \begin{bmatrix} N_1 & 0 & 0 & N_2 & 0 & 0 & \cdots \\ 0 & N_1 & 0 & 0 & N_2 & 0 & \cdots \\ 0 & 0 & N_1 & 0 & 0 & N_2 & \cdots \end{bmatrix}_{(3 \times 3N)} \begin{Bmatrix} u_1 \\ v_1 \\ w_1 \\ u_2 \\ v_2 \\ w_2 \\ \vdots \end{Bmatrix}_{(3N \times 1)} \tag{9}$$

or

$$\mathbf{u} = \mathbf{N} \mathbf{d}$$

Using relations (5) and (8), we can derive the strain vector

$$\begin{aligned}
 \boldsymbol{\varepsilon} &= \mathbf{B} \mathbf{d} \\
 (6 \times 1) \quad (6 \times 3N) \times (3N \times 1)
 \end{aligned}$$

Stiffness Matrix:

$$\mathbf{k} = \int_v \mathbf{B}^T \mathbf{E} \mathbf{B} dv \quad (10)$$

$(3 \times N) \quad (3N \times 6) \times (6 \times 6) \times (6 \times 3N)$

Numerical quadratures are often needed to evaluate the above integration.

Rigid-body motions for 3-D bodies (6 components):

3 translations, 3 rotations.

These rigid-body motions (causes of singularity of the system of equations) must be removed from the FEA model to ensure the quality of the analysis.

III. Typical 3-D Solid Elements

Tetrahedron:

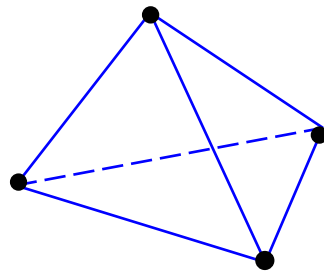

linear (4 nodes)

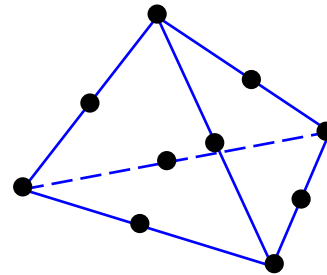

quadratic (10 nodes)

Hexahedron (brick):

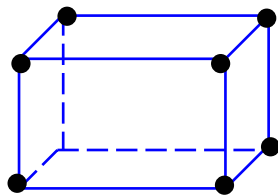

linear (8 nodes)

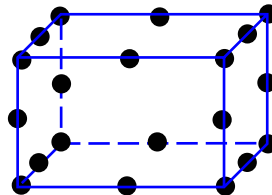

quadratic (20 nodes)

Penta:

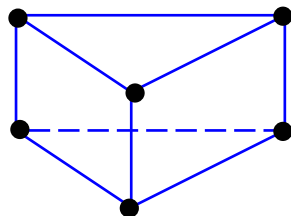

linear (6 nodes)

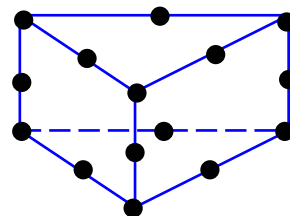

quadratic (15 nodes)

Avoid using the linear (4-node) tetrahedron element in 3-D stress analysis (Inaccurate! However, it is OK for static deformation or vibration analysis).

Element Formulation: Linear Hexahedron Element

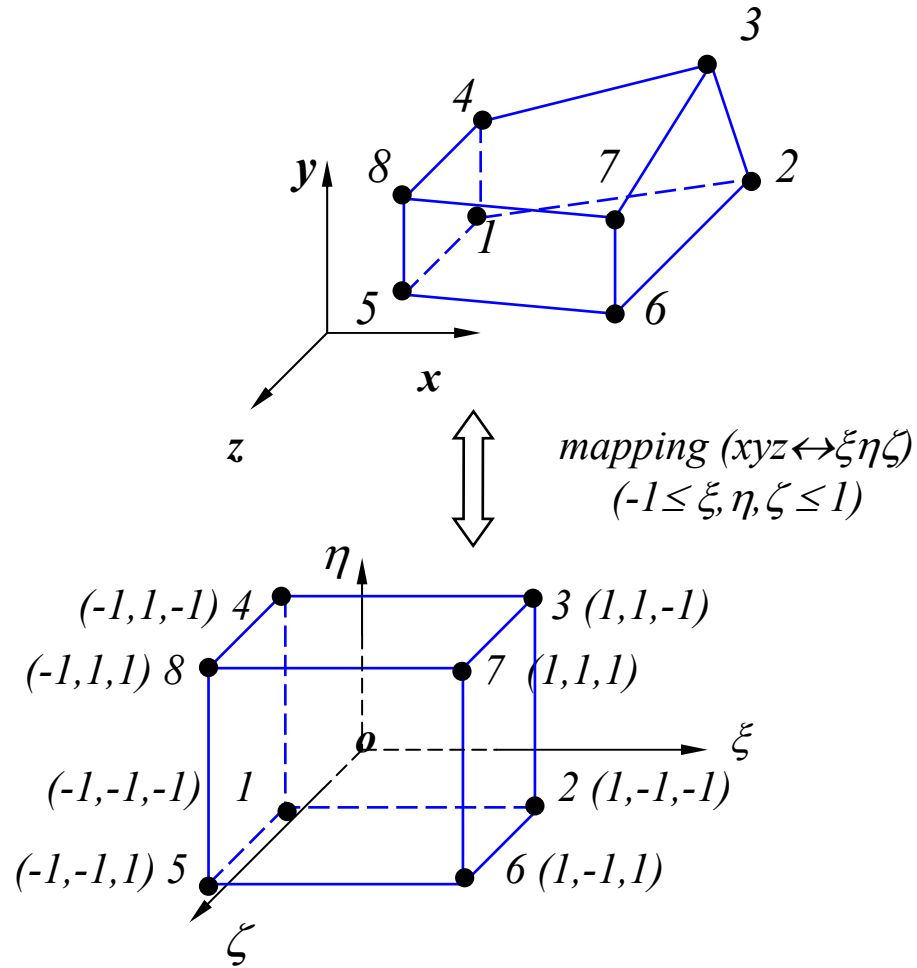

Displacement field in the element:

$$u = \sum_{i=1}^8 N_i u_i, \quad v = \sum_{i=1}^8 N_i v_i, \quad w = \sum_{i=1}^8 N_i w_i \quad (11)$$

Shape functions:

$$\begin{aligned}
N_1(\xi, \eta, \zeta) &= \frac{1}{8}(1-\xi)(1-\eta)(1-\zeta) \quad , \\
N_2(\xi, \eta, \zeta) &= \frac{1}{8}(1+\xi)(1-\eta)(1-\zeta) \quad , \\
N_3(\xi, \eta, \zeta) &= \frac{1}{8}(1+\xi)(1+\eta)(1-\zeta) \quad , \\
&\quad \vdots \qquad \qquad \qquad \vdots \\
N_8(\xi, \eta, \zeta) &= \frac{1}{8}(1-\xi)(1+\eta)(1+\zeta) \quad .
\end{aligned} \tag{12}$$

Note that we have the following relations for the shape functions:

$$\begin{aligned}
N_i(\xi_j, \eta_j, \zeta_j) &= \delta_{ij} \quad , \quad i, j = 1, 2, \dots, 8. \\
\sum_{i=1}^8 N_i(\xi, \eta, \zeta) &= 1.
\end{aligned}$$

Coordinate Transformation (Mapping):

$$x = \sum_{i=1}^8 N_i x_i \quad , \quad y = \sum_{i=1}^8 N_i y_i \quad , \quad z = \sum_{i=1}^8 N_i z_i \quad . \tag{13}$$

The same shape functions are used as for the displacement field.

\Rightarrow **Isoparametric element.**

Jacobian Matrix:

$$\begin{Bmatrix} \frac{\partial u}{\partial \xi} \\ \frac{\partial u}{\partial \eta} \\ \frac{\partial u}{\partial \zeta} \end{Bmatrix} = \begin{bmatrix} \frac{\partial x}{\partial \xi} & \frac{\partial y}{\partial \xi} & \frac{\partial z}{\partial \xi} \\ \frac{\partial x}{\partial \eta} & \frac{\partial y}{\partial \eta} & \frac{\partial z}{\partial \eta} \\ \frac{\partial x}{\partial \zeta} & \frac{\partial y}{\partial \zeta} & \frac{\partial z}{\partial \zeta} \end{bmatrix} \begin{Bmatrix} \frac{\partial u}{\partial x} \\ \frac{\partial u}{\partial y} \\ \frac{\partial u}{\partial z} \end{Bmatrix} \quad (14)$$

$\equiv \mathbf{J}$ *Jacobian matrix*

$$\Rightarrow \begin{Bmatrix} \frac{\partial u}{\partial x} \\ \frac{\partial u}{\partial y} \\ \frac{\partial u}{\partial z} \end{Bmatrix} = \mathbf{J}^{-1} \begin{Bmatrix} \frac{\partial u}{\partial \xi} \\ \frac{\partial u}{\partial \eta} \\ \frac{\partial u}{\partial \zeta} \end{Bmatrix}, \quad \left(\frac{\partial u}{\partial \xi} = \sum_{i=1}^8 \frac{\partial N_i}{\partial \xi} u_i, \text{ etc.} \right)$$

and

$$\begin{Bmatrix} \frac{\partial v}{\partial x} \\ \frac{\partial v}{\partial y} \\ \frac{\partial v}{\partial z} \end{Bmatrix} = \mathbf{J}^{-1} \begin{Bmatrix} \frac{\partial v}{\partial \xi} \\ \frac{\partial v}{\partial \eta} \\ \frac{\partial v}{\partial \zeta} \end{Bmatrix}, \quad (15)$$

also for w .

⇒

$$\boldsymbol{\varepsilon} = \begin{Bmatrix} \varepsilon_x \\ \varepsilon_y \\ \varepsilon_z \\ \gamma_{xy} \\ \gamma_{yz} \\ \gamma_{zx} \end{Bmatrix} = \begin{Bmatrix} \frac{\partial u}{\partial x} \\ \frac{\partial v}{\partial y} \\ \frac{\partial w}{\partial z} \\ \frac{\partial x}{\partial x} + \frac{\partial u}{\partial y} \\ \frac{\partial x}{\partial w} + \frac{\partial y}{\partial v} \\ \frac{\partial y}{\partial y} + \frac{\partial z}{\partial z} \\ \frac{\partial u}{\partial z} + \frac{\partial w}{\partial x} \\ \frac{\partial z}{\partial z} + \frac{\partial x}{\partial x} \end{Bmatrix} = \dots \text{use (15)} = \mathbf{B} \mathbf{d}$$

where \mathbf{d} is the nodal displacement vector,
i.e.,

$$\boldsymbol{\varepsilon} = \mathbf{B} \mathbf{d} \quad (16)$$

$$(6 \times 1) \quad (6 \times 24) \times (24 \times 1)$$

Strain energy,

$$\begin{aligned}
 U &= \frac{1}{2} \int_V \boldsymbol{\sigma}^T \boldsymbol{\varepsilon} dV = \frac{1}{2} \int_V (\mathbf{E}\boldsymbol{\varepsilon})^T \boldsymbol{\varepsilon} dV \\
 &= \frac{1}{2} \int_V \boldsymbol{\varepsilon}^T \mathbf{E} \boldsymbol{\varepsilon} dV \\
 &= \frac{1}{2} \mathbf{d}^T \left[\int_V \mathbf{B}^T \mathbf{E} \mathbf{B} dV \right] \mathbf{d}
 \end{aligned} \tag{17}$$

Element stiffness matrix,

$$\mathbf{k} = \int_V \mathbf{B}^T \mathbf{E} \mathbf{B} dV \tag{18}$$

$(24 \times 24) \quad (24 \times 6) \times (6 \times 6) \times (6 \times 24)$

In $\xi\eta\zeta$ coordinates:

$$dV = (\det \mathbf{J}) d\xi d\eta d\zeta \tag{19}$$

$$\Rightarrow \mathbf{k} = \int_{-1}^1 \int_{-1}^1 \int_{-1}^1 \mathbf{B}^T \mathbf{E} \mathbf{B} (\det \mathbf{J}) d\xi d\eta d\zeta \tag{20}$$

(Numerical integration)

- 3-D elements usually do not use rotational DOFs.

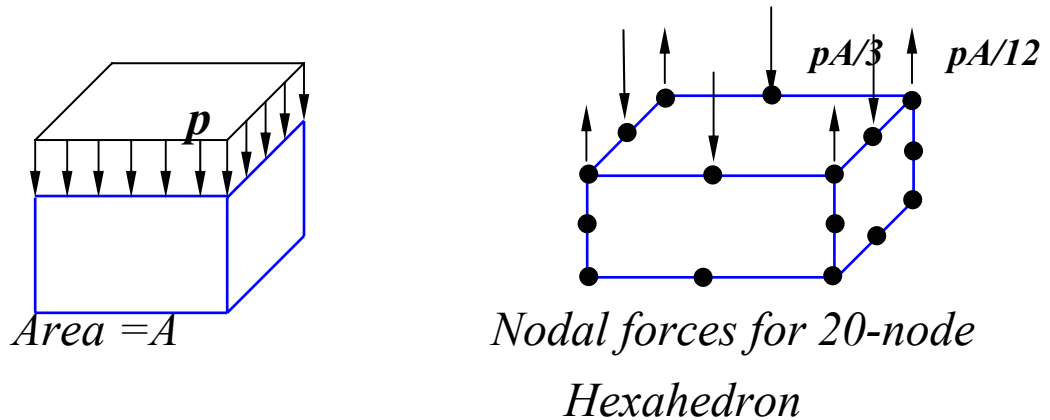
Treatment of distributed loads:Distributed loads \Rightarrow Nodal forces**Stresses:**

$$\boldsymbol{\sigma} = \mathbf{E} \boldsymbol{\varepsilon} = \mathbf{E} \mathbf{B} \mathbf{d}$$

Principal stresses:

$$\sigma_1, \sigma_2, \sigma_3.$$

von Mises stress:

$$\sigma_e = \sigma_{VM} = \frac{1}{\sqrt{2}} \sqrt{(\sigma_1 - \sigma_2)^2 + (\sigma_2 - \sigma_3)^2 + (\sigma_3 - \sigma_1)^2}.$$

Stresses are evaluated at selected points (including nodes) on each element. Averaging (around a node, for example) may be employed to smooth the field.

Examples: ...

Solids of Revolution (Axisymmetric Solids)

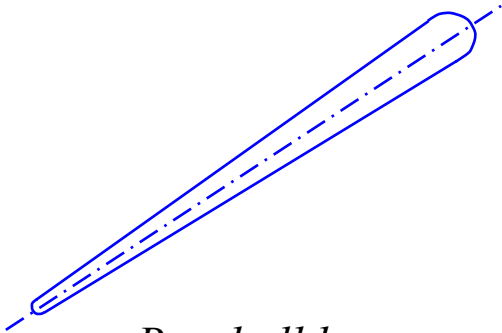

Baseball bat

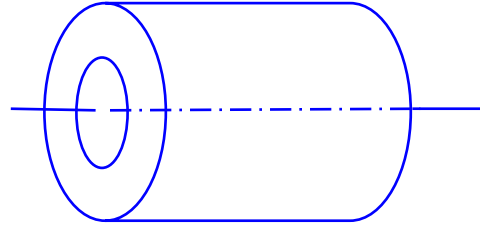

shaft

Apply cylindrical coordinates:

$$(x, y, z) \Rightarrow (r, \theta, z)$$

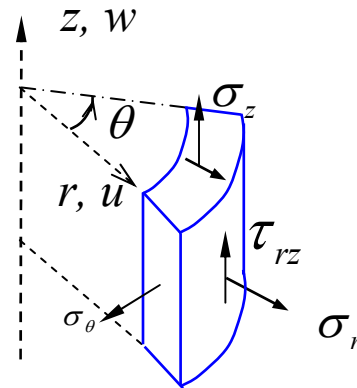
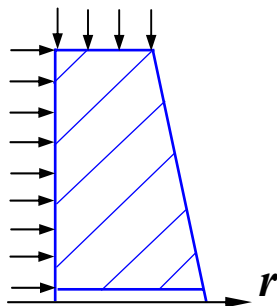
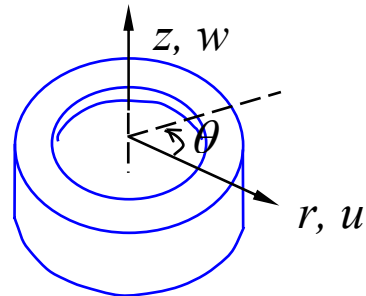
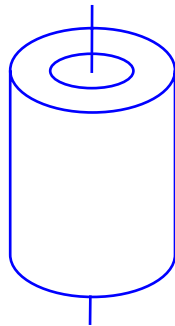

Displacement field:

$u = u(r, z)$, $w = w(r, z)$ (No v – circumferential component)

Strains:

$$\begin{aligned} \varepsilon_r &= \frac{\partial u}{\partial r} , & \varepsilon_\theta &= \frac{u}{r} , & \varepsilon_z &= \frac{\partial w}{\partial z} , \\ \gamma_{rz} &= \frac{\partial w}{\partial r} + \frac{\partial u}{\partial z} , & (\gamma_{r\theta} = \gamma_{z\theta} = 0) \end{aligned} \quad (21)$$

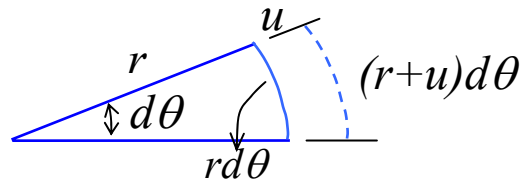
**Stresses:**

$$\begin{Bmatrix} \sigma_r \\ \sigma_\theta \\ \sigma_z \\ \tau_{rz} \end{Bmatrix} = \frac{E}{(1+\nu)(1-2\nu)} \begin{bmatrix} 1-\nu & \nu & \nu & 0 \\ \nu & 1-\nu & \nu & 0 \\ \nu & \nu & 1-\nu & 0 \\ 0 & 0 & 0 & \frac{1-2\nu}{2} \end{bmatrix} \begin{Bmatrix} \varepsilon_r \\ \varepsilon_\theta \\ \varepsilon_z \\ \gamma_{rz} \end{Bmatrix} \quad (22)$$

Axisymmetric Elements

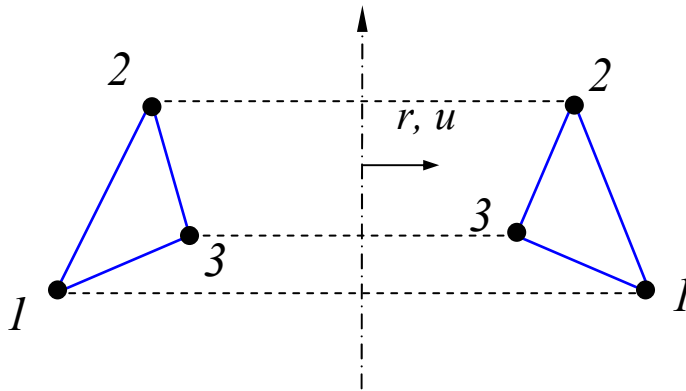

3-node element (ring)

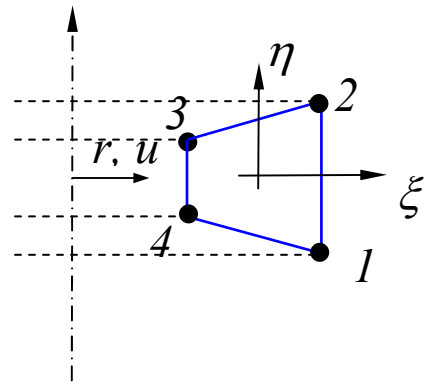

4-node element (ring)

$$\mathbf{k} = \int_V \mathbf{B}^T \mathbf{E} \mathbf{B} r dr d\theta dz \quad (23)$$

OR

$$\begin{aligned} \mathbf{k} &= \int_0^{2\pi} \int_{-1}^1 \int_{-1}^1 \mathbf{B}^T \mathbf{E} \mathbf{B} r (\det \mathbf{J}) d\xi d\eta d\theta \\ &= 2\pi \int_{-1}^1 \int_{-1}^1 \mathbf{B}^T \mathbf{E} \mathbf{B} r (\det \mathbf{J}) d\xi d\eta \end{aligned} \quad (24)$$

Applications

- **Rotating Flywheel:**

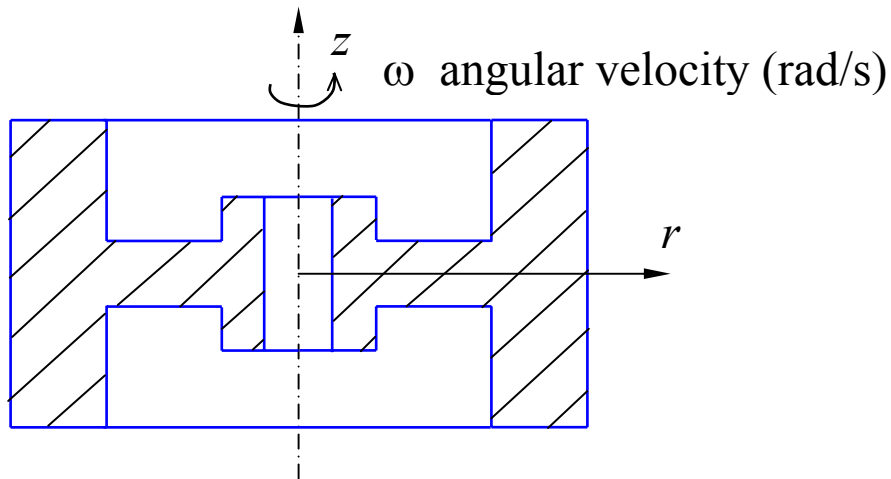

Body forces:

$$f_r = \rho r \omega^2 \quad (\text{equivalent radial centrifugal/ inertial force})$$

$$f_z = -\rho g \quad (\text{gravitational force})$$

• **Cylinder Subject to Internal Pressure:**

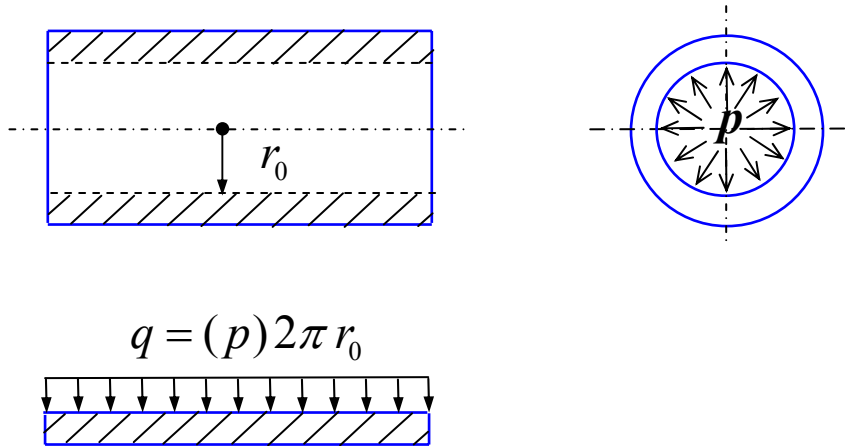

• **Press Fit:**

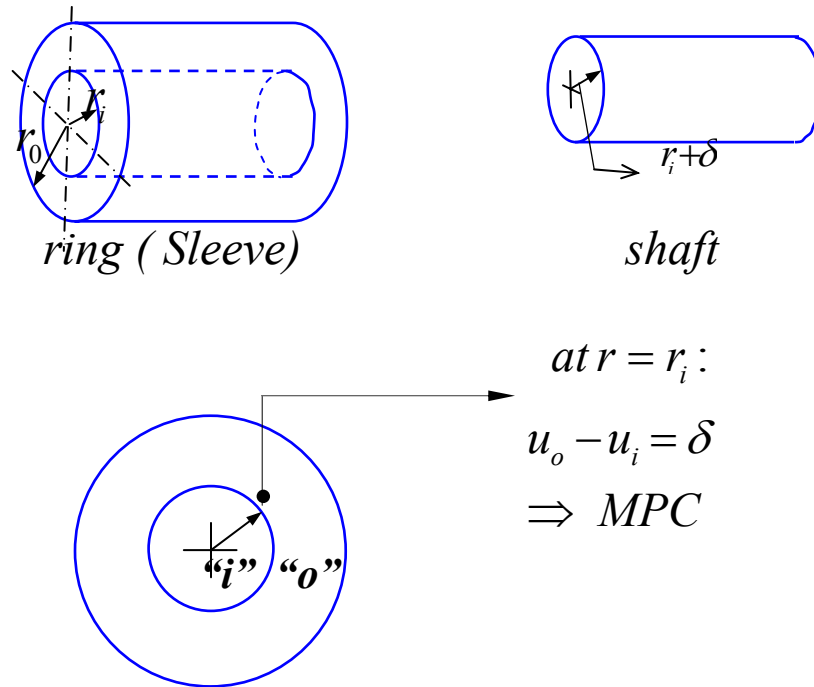

- **Belleville (Conical) Spring:**

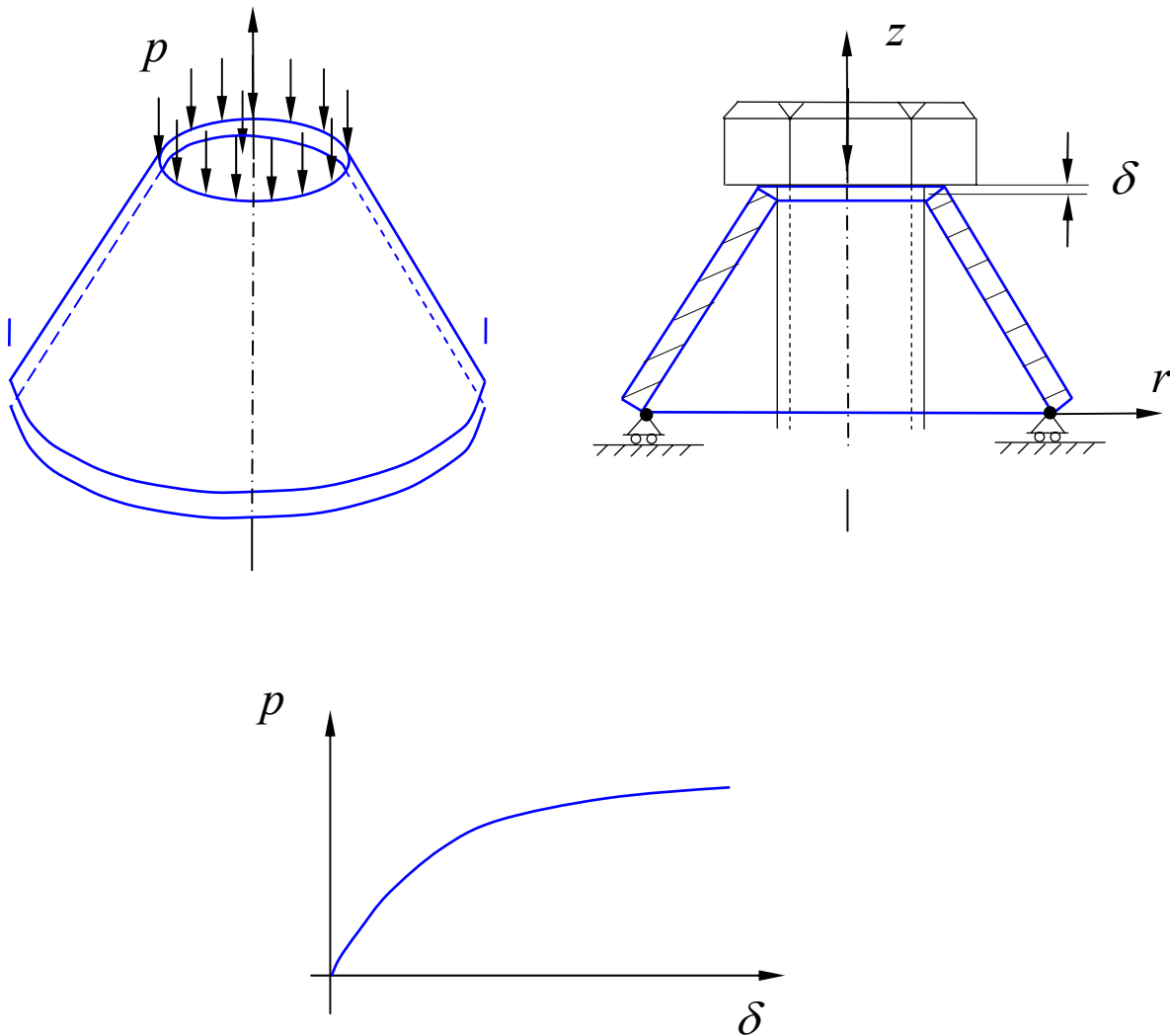

This is a geometrically nonlinear (large deformation) problem and iteration method (incremental approach) needs to be employed.

Chapter 7. Structural Vibration and Dynamics

- Natural frequencies and modes
- Frequency response ($F(t)=F_0 \sin \omega t$)
- Transient response ($F(t)$ arbitrary)

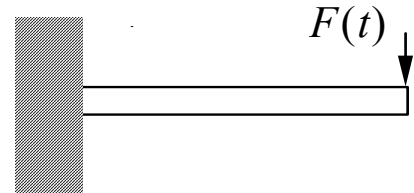

I. Basic Equations

A. Single DOF System

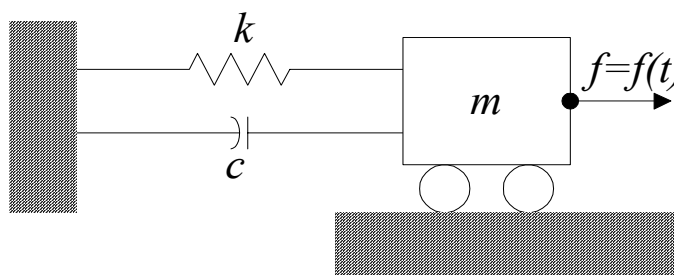

m - mass
 k - stiffness
 c - damping
 $f(t)$ - force

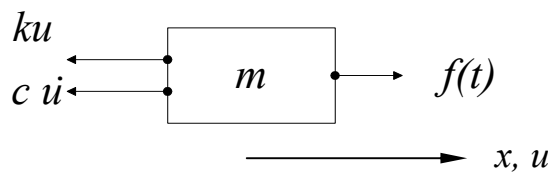

From Newton's law of motion ($ma = F$), we have

$$m\ddot{u} = f(t) - ku - c\dot{u},$$

i.e.

$$m\ddot{u} + c\dot{u} + ku = f(t), \quad (1)$$

where u is the displacement, $\dot{u} = du/dt$ and $\ddot{u} = d^2u/dt^2$.

Free Vibration: $f(t) = 0$ and no damping ($c = 0$)

Eq. (1) becomes

$$m\ddot{u} + ku = 0 \quad (2)$$

(meaning: inertia force + stiffness force = 0)

Assume:

$$u(t) = U \sin(\omega t),$$

where ω is the frequency of oscillation, U the amplitude.

Eq. (2) yields

$$-U\omega^2 m \sin(\omega t) + kU \sin(\omega t) = 0$$

i.e.,

$$[-\omega^2 m + k]U = 0.$$

For nontrivial solutions for U , we must have

$$[-\omega^2 m + k] = 0,$$

which yields

$$\omega = \sqrt{\frac{k}{m}} \quad (3)$$

This is the circular *natural frequency* of the single DOF system (rad/s). The cyclic frequency (1/s = Hz) is

$$f = \frac{\omega}{2\pi}, \quad (4)$$

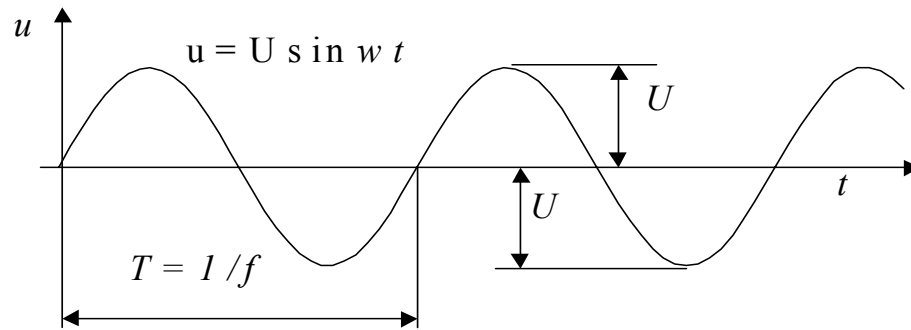

Undamped Free Vibration

With non-zero damping c , where

$$0 < c < c_c = 2m\omega = 2\sqrt{km} \quad (c_c = \text{critical damping}) \quad (5)$$

we have the damped natural frequency:

$$\omega_d = \omega\sqrt{1-\xi^2}, \quad (6)$$

where $\xi = \frac{c}{c_c}$ (damping ratio).

For structural damping: $0 \leq \xi < 0.15$ (usually 1~5%)

$$\omega_d \approx \omega. \quad (7)$$

Thus, we can ignore damping in normal mode analysis.

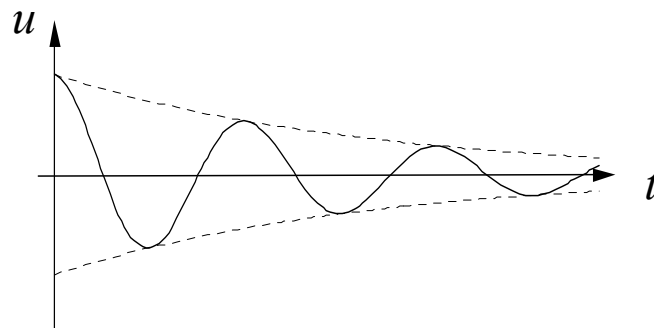
**Damped Free Vibration**

B. Multiple DOF System

Equation of Motion

Equation of motion for the whole structure is

$$\mathbf{M}\ddot{\mathbf{u}} + \mathbf{C}\dot{\mathbf{u}} + \mathbf{K}\mathbf{u} = \mathbf{f}(t), \quad (8)$$

in which: \mathbf{u} — nodal displacement vector,
 \mathbf{M} — mass matrix,
 \mathbf{C} — damping matrix,
 \mathbf{K} — stiffness matrix,
 \mathbf{f} — forcing vector.

Physical meaning of Eq. (8):

$$\begin{aligned} &\text{Inertia forces} + \text{Damping forces} + \text{Elastic forces} \\ &= \text{Applied forces} \end{aligned}$$

Mass Matrices

Lumped mass matrix (1-D bar element):

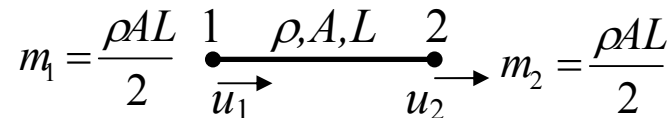

$$m_1 = \frac{\rho AL}{2} \quad \begin{array}{c} 1 \\ \bullet \\ \xrightarrow{u_1} \end{array} \quad \begin{array}{c} \rho, A, L \\ \text{---} \\ \bullet \\ \xrightarrow{u_2} \end{array} \quad m_2 = \frac{\rho AL}{2} \quad 2$$

Element mass matrix is found to be

$$\mathbf{m} = \underbrace{\begin{bmatrix} \frac{\rho AL}{2} & 0 \\ 0 & \frac{\rho AL}{2} \end{bmatrix}}_{\text{diagonal matrix}}$$

In general, we have the *consistent mass matrix* given by

$$\mathbf{m} = \int_V \rho \mathbf{N}^T \mathbf{N} dV \quad (9)$$

where \mathbf{N} is the same shape function matrix as used for the displacement field.

This is obtained by considering the kinetic energy:

$$\begin{aligned} K &= \frac{1}{2} \dot{\mathbf{u}}^T \mathbf{m} \dot{\mathbf{u}} && \text{(cf. } \frac{1}{2} m v^2 \text{)} \\ &= \frac{1}{2} \int_V \rho \dot{u}^2 dV = \frac{1}{2} \int_V \rho (\dot{u})^T \dot{u} dV \\ &= \frac{1}{2} \int_V \rho (\mathbf{N} \dot{\mathbf{u}})^T (\mathbf{N} \dot{\mathbf{u}}) dV \\ &= \frac{1}{2} \dot{\mathbf{u}}^T \underbrace{\int_V \rho \mathbf{N}^T \mathbf{N} dV}_{\mathbf{m}} \dot{\mathbf{u}} \end{aligned}$$

Bar Element (linear shape function):

$$\begin{aligned} \mathbf{m} &= \int_V \rho \begin{bmatrix} 1 - \xi \\ \xi \end{bmatrix} \begin{bmatrix} 1 - \xi & \xi \end{bmatrix} AL d\xi \\ &= \rho AL \begin{bmatrix} 1/3 & 1/6 \\ 1/6 & 1/3 \end{bmatrix} \begin{bmatrix} \ddot{u}_1 \\ \ddot{u}_2 \end{bmatrix} \end{aligned} \quad (10)$$

Element mass matrices:

⇒ local coordinates ⇒ to global coordinates

⇒ assembly of the global structure mass matrix \mathbf{M} .

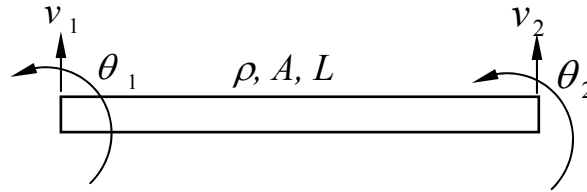
Example**Simple Beam Element:**

$$\mathbf{m} = \int_V \rho \mathbf{N}^T \mathbf{N} dV$$

$$= \frac{\rho AL}{420} \begin{bmatrix} 156 & 22L & 54 & -13L \\ 22L & 4L^2 & 13L & -3L^2 \\ 54 & 13L & 156 & -22L \\ -13L & -3L^2 & -22L & 4L^2 \end{bmatrix} \begin{bmatrix} \ddot{v}_1 \\ \ddot{\theta}_1 \\ \ddot{v}_2 \\ \ddot{\theta}_2 \end{bmatrix} \quad (11)$$

Units in dynamic analysis (make sure they are consistent):

	Choice I	Choice II
<i>t (time)</i>	s	s
<i>L (length)</i>	m	mm
<i>m (mass)</i>	kg	Mg
<i>a (accel.)</i>	m/s ²	mm/s ²
<i>f (force)</i>	N	N
<i>ρ (density)</i>	kg/m ³	Mg/mm ³

II. Free Vibration

Study of the dynamic characteristics of a structure:

- natural frequencies
- normal modes (shapes)

Let $\mathbf{f}(t) = \mathbf{0}$ and $\mathbf{C} = \mathbf{0}$ (ignore damping) in the dynamic equation (8) and obtain

$$\mathbf{M}\ddot{\mathbf{u}} + \mathbf{K}\mathbf{u} = \mathbf{0} \quad (12)$$

Assume that displacements vary harmonically with time, that is,

$$\begin{aligned}\mathbf{u}(t) &= \bar{\mathbf{u}} \sin(\omega t), \\ \dot{\mathbf{u}}(t) &= \omega \bar{\mathbf{u}} \cos(\omega t), \\ \ddot{\mathbf{u}}(t) &= -\omega^2 \bar{\mathbf{u}} \sin(\omega t),\end{aligned}$$

where $\bar{\mathbf{u}}$ is the vector of nodal displacement amplitudes.

Eq. (12) yields,

$$[\mathbf{K} - \omega^2 \mathbf{M}] \bar{\mathbf{u}} = \mathbf{0} \quad (13)$$

This is a generalized eigenvalue problem (EVP).

Solutions?

Trivial solution: $\bar{\mathbf{u}} = \mathbf{0}$ for any values of ω (not interesting).

Nontrivial solutions: $\bar{\mathbf{u}} \neq \mathbf{0}$ only if

$$|\mathbf{K} - \omega^2 \mathbf{M}| = 0 \quad (14)$$

This is an n-th order polynomial of ω^2 , from which we can find n solutions (roots) or eigenvalues ω_i .

ω_i ($i = 1, 2, \dots, n$) are the natural frequencies (or characteristic frequencies) of the structure.

ω_1 (the smallest one) is called the fundamental frequency.

For each ω_i , Eq. (13) gives one solution (or eigen) vector

$$[\mathbf{K} - \omega_i^2 \mathbf{M}] \bar{\mathbf{u}}_i = \mathbf{0} .$$

$\bar{\mathbf{u}}_i$ ($i=1,2,\dots,n$) are the *normal modes* (or *natural modes*, *mode shapes*, etc.).

Properties of Normal Modes

$$\bar{\mathbf{u}}_i^T \mathbf{K} \bar{\mathbf{u}}_j = 0 ,$$

$$\bar{\mathbf{u}}_i^T \mathbf{M} \bar{\mathbf{u}}_j = 0 , \quad \text{for } i \neq j, \quad (15)$$

if $\omega_i \neq \omega_j$. That is, modes are orthogonal (or independent) to each other with respect to \mathbf{K} and \mathbf{M} matrices.

Normalize the modes:

$$\begin{aligned}\bar{\mathbf{u}}_i^T \mathbf{M} \bar{\mathbf{u}}_i &= 1, \\ \bar{\mathbf{u}}_i^T \mathbf{K} \bar{\mathbf{u}}_i &= \omega_i^2.\end{aligned}\tag{16}$$

Note:

- Magnitudes of displacements (modes) or stresses in normal mode analysis have no physical meaning.
- For normal mode analysis, no support of the structure is necessary.
 - $\omega_i = 0 \Leftrightarrow$ there are rigid body motions of the whole or a part of the structure.
 - \Rightarrow apply this to check the FEA model (check for mechanism or free elements in the models).
- Lower modes are more accurate than higher modes in the FE calculations (less spatial variations in the lower modes \Rightarrow fewer elements/wave length are needed).

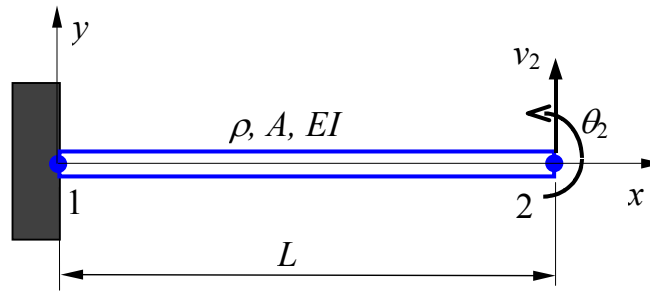
Example:

$$[\mathbf{K} - \omega^2 \mathbf{M}] \begin{Bmatrix} \bar{v}_2 \\ \bar{\theta}_2 \end{Bmatrix} = \begin{Bmatrix} 0 \\ 0 \end{Bmatrix},$$

$$\mathbf{K} = \frac{EI}{L^3} \begin{bmatrix} 12 & -6L \\ -6L & 4L^2 \end{bmatrix}, \quad \mathbf{M} = \frac{\rho AL}{420} \begin{bmatrix} 156 & -22L \\ -22L & 4L^2 \end{bmatrix}.$$

$$\text{EVP:} \quad \begin{vmatrix} 12 - 156\lambda & -6L + 22L\lambda \\ -6L + 22L\lambda & 4L^2 - 4L^2\lambda \end{vmatrix} = 0,$$

in which $\lambda = \omega^2 \rho AL^4 / 420 EI$.

Solving the EVP, we obtain,

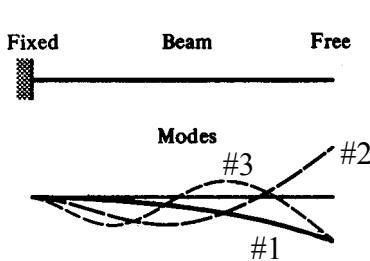

$$\omega_1 = 3.533 \left(\frac{EI}{\rho AL^4} \right)^{1/2}, \quad \begin{Bmatrix} \bar{v}_2 \\ \bar{\theta}_2 \end{Bmatrix}_1 = \begin{Bmatrix} 1 \\ 1.38/L \end{Bmatrix},$$

$$\omega_2 = 34.81 \left(\frac{EI}{\rho AL^4} \right)^{1/2}, \quad \begin{Bmatrix} \bar{v}_2 \\ \bar{\theta}_2 \end{Bmatrix}_2 = \begin{Bmatrix} 1 \\ 7.62/L \end{Bmatrix}.$$

Exact solutions:

$$\omega_1 = 3.516 \left(\frac{EI}{\rho AL^4} \right)^{1/2}, \quad \omega_2 = 22.03 \left(\frac{EI}{\rho AL^4} \right)^{1/2}.$$

We can see that mode 1 is calculated much more accurately than mode 2, with one beam element.

III. Damping

Two commonly used models for viscous damping.

A. Proportional Damping (Rayleigh Damping)

$$\mathbf{C} = \alpha\mathbf{M} + \beta\mathbf{K} \quad (17)$$

where the constants α & β are found from

$$\xi_1 = \frac{\alpha\omega_1}{2} + \frac{\beta}{2\omega_1}, \quad \xi_2 = \frac{\alpha\omega_2}{2} + \frac{\beta}{2\omega_2},$$

with $\omega_1, \omega_2, \xi_1$ & ξ_2 (damping ratio) being selected.

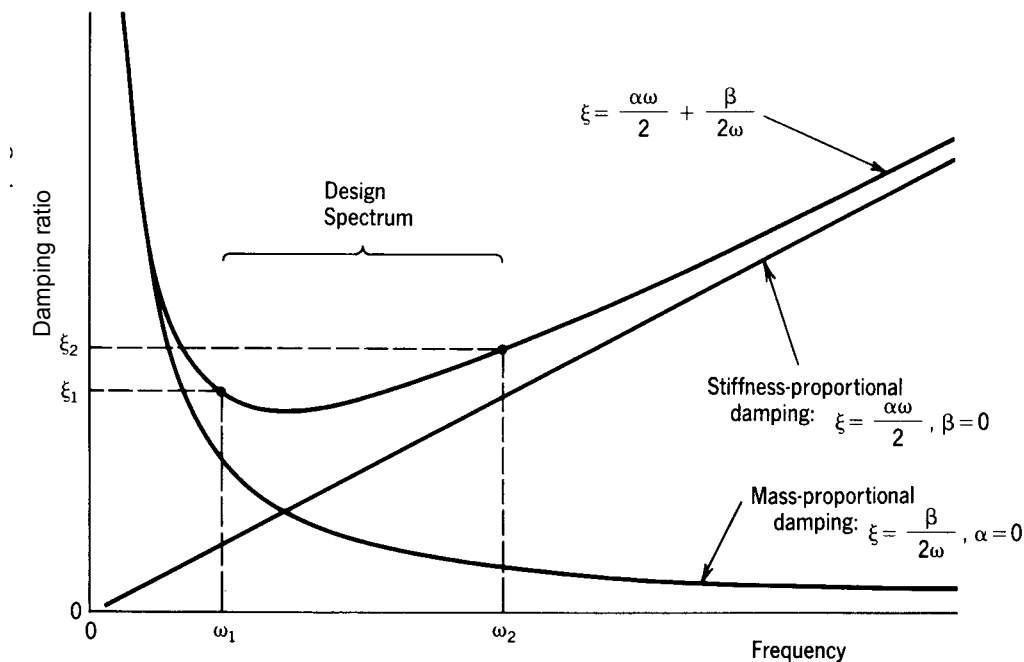

B. Modal Damping

Incorporate the viscous damping in modal equations.

IV. Modal Equations

Use the normal modes (modal matrix) to transform the coupled system of dynamic equations to uncoupled system of equations.

We have

$$[\mathbf{K} - \omega_i^2 \mathbf{M}] \bar{\mathbf{u}}_i = \mathbf{0}, \quad i = 1, 2, \dots, n \quad (18)$$

where the normal mode $\bar{\mathbf{u}}_i$ satisfies:

$$\begin{cases} \bar{\mathbf{u}}_i^T \mathbf{K} \bar{\mathbf{u}}_j = 0, \\ \bar{\mathbf{u}}_i^T \mathbf{M} \bar{\mathbf{u}}_j = 0, \end{cases} \quad \text{for } i \neq j,$$

and

$$\begin{cases} \bar{\mathbf{u}}_i^T \mathbf{M} \bar{\mathbf{u}}_i = 1, \\ \bar{\mathbf{u}}_i^T \mathbf{K} \bar{\mathbf{u}}_i = \omega_i^2, \end{cases} \quad \text{for } i = 1, 2, \dots, n.$$

Form the *modal matrix*:

$$\Phi_{(n \times n)} = [\bar{\mathbf{u}}_1 \quad \bar{\mathbf{u}}_2 \quad \dots \quad \bar{\mathbf{u}}_n] \quad (19)$$

We can verify that

$$\Phi^T \mathbf{K} \Phi = \mathbf{\Omega} = \begin{bmatrix} \omega_1^2 & 0 & \dots & 0 \\ 0 & \omega_2^2 & & \vdots \\ \vdots & & \ddots & 0 \\ 0 & \dots & 0 & \omega_n^2 \end{bmatrix} \quad (\text{Spectral matrix}) \quad (20)$$

$$\Phi^T \mathbf{M} \Phi = \mathbf{I}.$$

Transformation for the displacement vector,

$$\mathbf{u} = z_1 \bar{\mathbf{u}}_1 + z_2 \bar{\mathbf{u}}_2 + \dots + z_n \bar{\mathbf{u}}_n = \Phi \mathbf{z}, \quad (21)$$

where

$$\mathbf{z} = \begin{Bmatrix} z_1(t) \\ z_2(t) \\ \vdots \\ z_n(t) \end{Bmatrix}$$

are called *principal coordinates*.

Substitute (21) into the dynamic equation:

$$\mathbf{M} \Phi \dot{\mathbf{z}} + \mathbf{C} \Phi \dot{\mathbf{z}} + \mathbf{K} \Phi \mathbf{z} = \mathbf{f}(t).$$

Pre-multiply by Φ^T , and apply (20):

$$\ddot{\mathbf{z}} + \mathbf{C}_\phi \dot{\mathbf{z}} + \Omega \mathbf{z} = \mathbf{p}(t), \quad (22)$$

where $\mathbf{C}_\phi = \alpha \mathbf{I} + \beta \Omega$ (for proportional damping),

$$\mathbf{p} = \Phi^T \mathbf{f}(t).$$

Introduce *modal damping*:

$$\mathbf{C}_\phi = \begin{bmatrix} 2\xi_1\omega_1 & 0 & \cdots & 0 \\ 0 & 2\xi_2\omega_2 & & \\ \vdots & & \ddots & \vdots \\ 0 & & \cdots & 2\xi_n\omega_n \end{bmatrix}. \quad (23)$$

Equation (22) becomes,

$$\ddot{z}_i + 2\xi_i\omega_i\dot{z}_i + \omega_i^2 z_i = p_i(t), \quad i = 1, 2, \dots, n. \quad (24)$$

Equations in (22) or (24) are called *modal equations*. These equations are uncoupled, second-order differential equations, which are much easier to solve than the original dynamic equation (a coupled system).

To recover \mathbf{u} from \mathbf{z} , apply transformation (21) again, once \mathbf{z} is obtained from (24).

Notes:

- Only the first few modes may be needed in constructing the modal matrix Φ (i.e., Φ could be an $n \times m$ rectangular matrix with $m < n$). Thus, significant reduction in the size of the system can be achieved.
- Modal equations are best suited for problems in which higher modes are not important (i.e., structural vibrations, but not for structures under a shock load).

V. Frequency Response Analysis

(Harmonic Response Analysis)

$$\mathbf{M}\ddot{\mathbf{u}} + \mathbf{C}\dot{\mathbf{u}} + \mathbf{K}\mathbf{u} = \underbrace{\mathbf{F}\sin\omega t}_{\text{Harmonic loading}} \quad (25)$$

Modal method: Apply the modal equations,

$$\ddot{z}_i + 2\xi_i\omega_i\dot{z}_i + \omega_i^2 z_i = p_i \sin \omega t, \quad i=1,2,\dots,m. \quad (26)$$

These are 1-D equations. Solutions are

$$z_i(t) = \frac{p_i/\omega_i^2}{\sqrt{(1-\eta_i^2)^2 + (2\xi_i\eta_i)^2}} \sin(\omega t - \theta_i), \quad (27)$$

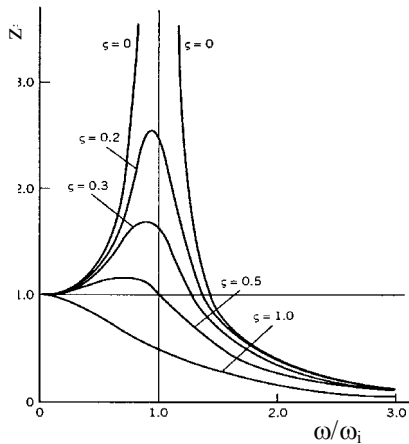

where

$$\left\{ \begin{array}{l} \theta_i = \arctan \frac{2\xi_i\eta_i}{1-\eta_i^2}, \text{ phase angle} \\ \eta_i = \omega/\omega_i, \\ \xi_i = \frac{c_i}{c_c} = \frac{c_i}{2m\omega_i}, \text{ damping ratio} \end{array} \right.$$

Recover \mathbf{u} from (21).

Direct Method: Solve Eq. (25) directly, that is, calculate the inverse. With $\mathbf{u} = \bar{\mathbf{u}} e^{i\omega t}$ (complex notation), Eq. (25) becomes

$$\left[\mathbf{K} + i\omega \mathbf{C} - \omega^2 \mathbf{M} \right] \bar{\mathbf{u}} = \bar{\mathbf{F}}.$$

This equation is expensive to solve and matrix is ill-conditioned if ω is close to any ω_i .

VI. Transient Response Analysis

(Dynamic Response/Time-History Analysis)

- Structure response to *arbitrary, time-dependent loading*.

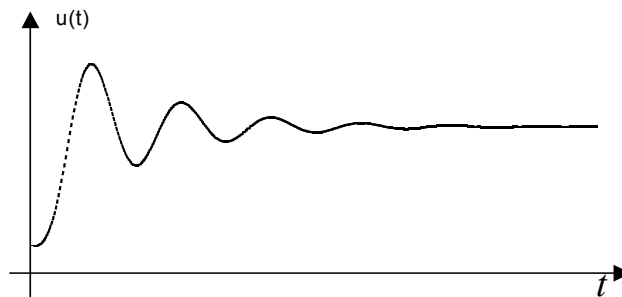
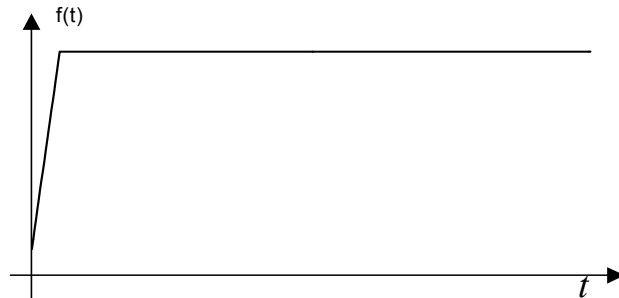

Compute responses by integrating through time:

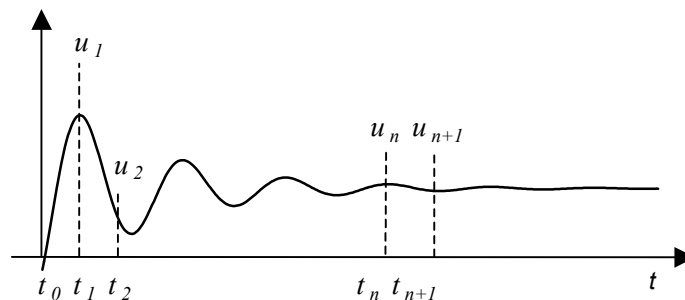

Equation of motion at instance t_n , $n = 0, 1, 2, 3, \dots$:

$$\mathbf{M}\ddot{\mathbf{u}}_n + \mathbf{C}\dot{\mathbf{u}}_n + \mathbf{K}\mathbf{u}_n = \mathbf{f}_n.$$

Time increment: $\Delta t = t_{n+1} - t_n$, $n = 0, 1, 2, 3, \dots$.

There are two categories of methods for transient analysis.

A. Direct Methods (Direct Integration Methods)

- **Central Difference Method**

Approximate using finite difference:

$$\dot{\mathbf{u}}_n = \frac{1}{2\Delta t} (\mathbf{u}_{n+1} - \mathbf{u}_{n-1}),$$

$$\ddot{\mathbf{u}}_n = \frac{1}{(\Delta t)^2} (\mathbf{u}_{n+1} - 2\mathbf{u}_n + \mathbf{u}_{n-1})$$

Dynamic equation becomes,

$$\mathbf{M} \left[\frac{1}{(\Delta t)^2} (\mathbf{u}_{n+1} - 2\mathbf{u}_n + \mathbf{u}_{n-1}) \right] + \mathbf{C} \left[\frac{1}{2\Delta t} (\mathbf{u}_{n+1} - \mathbf{u}_{n-1}) \right] + \mathbf{K}\mathbf{u}_n = \mathbf{f}_n,$$

which yields,

$$\mathbf{A}\mathbf{u}_{n+1} = \mathbf{F}(t)$$

where

$$\left\{ \begin{array}{l} \mathbf{A} = \frac{1}{(\Delta t)^2} \mathbf{M} + \frac{1}{2\Delta t} \mathbf{C}, \\ \mathbf{F}(t) = \mathbf{f}_n - \left[\mathbf{K} - \frac{2}{(\Delta t)^2} \mathbf{M} \right] \mathbf{u}_n - \left[\frac{1}{(\Delta t)^2} \mathbf{M} - \frac{1}{2\Delta t} \mathbf{C} \right] \mathbf{u}_{n-1}. \end{array} \right.$$

\mathbf{u}_{n+1} is calculated from \mathbf{u}_n & \mathbf{u}_{n-1} , and solution is marching from $t_0, t_1, \dots, t_n, t_{n+1}, \dots$, until convergent.

This method is *unstable* if Δt is too large.

- **Newmark Method:**

Use approximations:

$$\mathbf{u}_{n+1} \approx \mathbf{u}_n + \Delta t \dot{\mathbf{u}}_n + \frac{(\Delta t)^2}{2} [(1 - 2\beta)\ddot{\mathbf{u}}_n + 2\beta\ddot{\mathbf{u}}_{n+1}] \rightarrow (\ddot{\mathbf{u}}_{n+1} = \dots)$$

$$\dot{\mathbf{u}}_{n+1} \approx \dot{\mathbf{u}}_n + \Delta t [(1 - \gamma)\ddot{\mathbf{u}}_n + \gamma\ddot{\mathbf{u}}_{n+1}]$$

where β & γ are chosen constants. These lead to

$$\mathbf{A} \mathbf{u}_{n+1} = \mathbf{F}(t)$$

where

$$\mathbf{A} = \mathbf{K} + \frac{\gamma}{\beta \Delta t} \mathbf{C} + \frac{1}{\beta (\Delta t)^2} \mathbf{M},$$

$$\mathbf{F}(t) = f(\mathbf{f}_{n+1}, \gamma, \beta, \Delta t, \mathbf{C}, \mathbf{M}, \mathbf{u}_n, \dot{\mathbf{u}}_n, \ddot{\mathbf{u}}_n).$$

This method is *unconditionally stable* if

$$2\beta \geq \gamma \geq \frac{1}{2}.$$

$$\text{e.g., } \gamma = \frac{1}{2}, \beta = \frac{1}{4}$$

which gives the constant average acceleration method.

Direct methods can be expensive! (the need to compute \mathbf{A}^{-1} , often repeatedly for each time step).

B. Modal Method

First, do the transformation of the dynamic equations using the modal matrix before the time marching:

$$\mathbf{u} = \sum_{i=1}^m \bar{\mathbf{u}}_i z_i(t) = \Phi \mathbf{z}, \quad i = 1, 2, \dots, m.$$

$$\ddot{z}_i + 2\xi_i \omega_i \dot{z}_i + \omega_i^2 z_i = p_i(t),$$

Then, solve the uncoupled equations using an integration method. Can use, e.g., 10% of the total modes ($m = n/10$).

- Uncoupled system,
- Fewer equations,
- No inverse of matrices,
- More efficient for large problems.

Comparisons of the Methods

<i>Direct Methods</i>	<i>Modal Method</i>
<ul style="list-style-type: none"> • Small model • More accurate (with small Δt) • Single loading • Shock loading • ... 	<ul style="list-style-type: none"> • Large model • Higher modes ignored • Multiple loading • Periodic loading • ...

Cautions in Dynamic Analysis

- *Symmetry*: It should not be used in the dynamic analysis (normal modes, etc.) because symmetric structures can have antisymmetric modes.
- Mechanism, rigid body motion means $\omega = 0$. Can use this to check FEA models to see if they are properly connected and/or supported.

Input for FEA: loading $F(t)$ or $F(\omega)$ can be very complicated in real applications and often needs to be filtered first before used as input for FEA.

Examples

Impact, drop tests, etc.

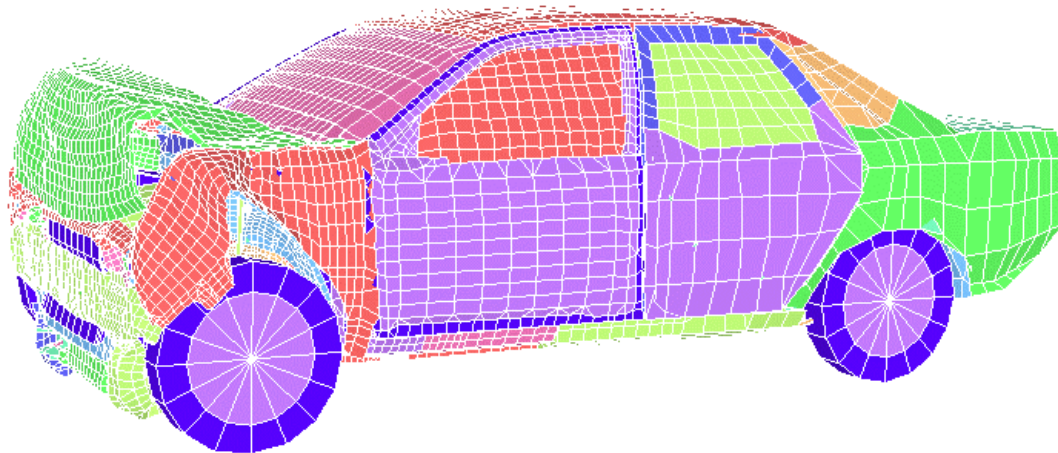

Crash Analysis for a Car (from [LS-DYNA3D](#))

Chapter 8. Thermal Analysis

Two objectives:

- Determine the temperature field (steady or unsteady state)
- Stresses due to the temperature changes

I. Temperature Field

Fourier Heat Conduction Equation:

1-D Case:

$$f_x = -k \frac{\partial T}{\partial x}, \quad (1)$$

where,

f_x = heat flux per unit area,
 k = thermal conductivity,
 $T = T(x)$ = temperature.

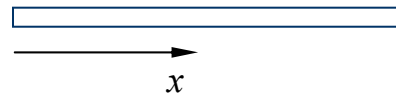

3-D Case:

$$\begin{Bmatrix} f_x \\ f_y \\ f_z \end{Bmatrix} = -\mathbf{K} \begin{Bmatrix} \partial T / \partial x \\ \partial T / \partial y \\ \partial T / \partial z \end{Bmatrix}, \quad (2)$$

where, f_x, f_y, f_z = heat flux in x, y and z direction, respectively,
 and in case of isotropy,

$$\mathbf{K} = \begin{bmatrix} k & 0 & 0 \\ 0 & k & 0 \\ 0 & 0 & k \end{bmatrix}. \quad (3)$$

The Equation of Heat Flow is:

$$-\left[\frac{\partial f_x}{\partial x} + \frac{\partial f_y}{\partial y} + \frac{\partial f_z}{\partial z} \right] + q_v = c\rho \frac{\partial T}{\partial t} \quad (4)$$

in which,

q_v = rate of internal heat generation per unit volume,

c = specific heat,

ρ = mass density.

For steady state ($\partial T/\partial t = 0$) and isotropic materials, we can obtain:

$$k\nabla^2 T = -q_v. \quad (5)$$

This a Poisson equation.

Boundary Conditions (BC's):

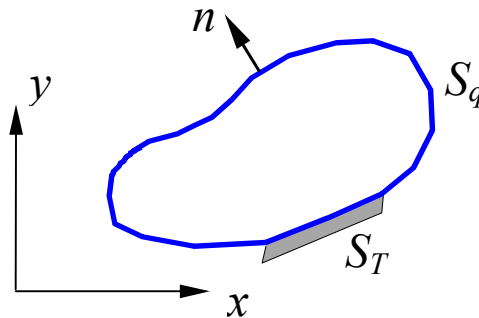

$$\begin{aligned} T &= \bar{T}, & \text{on } S_T; \\ \frac{\partial T}{\partial n} &= \bar{Q}, & \text{on } S_q. \end{aligned} \quad (6)$$

Note that at any point on the boundary $S = S_T \cup S_q$, only one type of BC can be specified.

Finite Element Formulation for Heat Conduction:

$$\mathbf{K}_T \mathbf{T} = \mathbf{q} \quad (7)$$

where,

\mathbf{K}_T = conductivity matrix,

\mathbf{T} = vector of nodal temperature,

\mathbf{q} = vector of thermal loads.

The element conductivity matrix is given by:

$$\mathbf{k}_T = \int_V \mathbf{B}^T \mathbf{K} \mathbf{B} dV. \quad (8)$$

This is obtained in a similar way as for the structural analysis, e.g., by starting with the interpolation $T = \mathbf{N} \mathbf{T}_e$ (\mathbf{N} is the shape function matrix, T_e the nodal temperature).

Note that there is only one DOF at each node for the thermal problems.

Thermal Transient Analysis:

$$\frac{\partial T}{\partial t} \neq 0.$$

Apply FDM (use time steps and integrate in time), as in the transient structural analysis, to obtain the transient temperature fields.

II. Thermal Stress Analysis

- Solve Eq. (7) first to obtain the temperature (change) fields.
- Apply the temperature change ΔT as initial strains (or initial stresses) to the structure.

1-D Case:

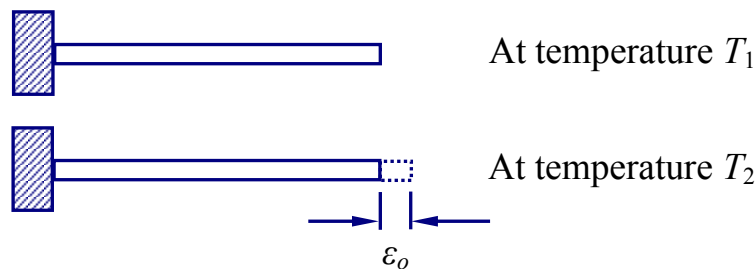

Thermal Strain (Initial Strain):

$$\epsilon_o = \alpha \Delta T, \quad (9)$$

in which,

α = the coefficient of thermal expansion,

$\Delta T = T_2 - T_1$ is the change of temperature.

Total strain,

$$\epsilon = \epsilon_e + \epsilon_o \quad (10)$$

with ϵ_e being the elastic strain due to mechanical load.

That is,

$$\epsilon = E^{-1} \sigma + \alpha \Delta T, \quad (11)$$

$$\text{or } \sigma = E(\epsilon - \epsilon_o). \quad (12)$$

Example: The above shown bar under thermal load ΔT .

- (a) If no constraint on the right-hand side, that is, the bar is free to expand to the right, then

$$\varepsilon = \varepsilon_o, \quad \varepsilon_e = 0, \quad \sigma = 0,$$

from Eq. (12). No thermal stress!

- (b) If there is a constraint on the right-hand side, that is, the bar can not expand to the right, then

$$\varepsilon = 0, \quad \varepsilon_e = -\varepsilon_o = -\alpha\Delta T, \quad \sigma = -E\alpha\Delta T,$$

from Eqs. (10) and (12). Thus, thermal stress exists!

2-D Cases:

Plane Stress,

$$\boldsymbol{\varepsilon}_o = \begin{Bmatrix} \varepsilon_x \\ \varepsilon_y \\ \gamma_{xy} \end{Bmatrix}_o = \begin{Bmatrix} \alpha\Delta T \\ \alpha\Delta T \\ 0 \end{Bmatrix}. \quad (13)$$

Plane Strain,

$$\boldsymbol{\varepsilon}_o = \begin{Bmatrix} \varepsilon_x \\ \varepsilon_y \\ \gamma_{xy} \end{Bmatrix}_o = \begin{Bmatrix} (1+\nu)\alpha\Delta T \\ (1+\nu)\alpha\Delta T \\ 0 \end{Bmatrix}. \quad (14)$$

Here, ν is the Poisson's ratio.

3-D Case:

$$\boldsymbol{\varepsilon}_o = \begin{Bmatrix} \varepsilon_x \\ \varepsilon_y \\ \varepsilon_z \\ \gamma_{xy} \\ \gamma_{yz} \\ \gamma_{zx} \end{Bmatrix}_o = \begin{Bmatrix} \alpha\Delta T \\ \alpha\Delta T \\ \alpha\Delta T \\ 0 \\ 0 \\ 0 \end{Bmatrix}. \quad (15)$$

Observation: Temperature changes do not yield shear strains.

Total Strain:

$$\boldsymbol{\varepsilon} = \boldsymbol{\varepsilon}_e + \boldsymbol{\varepsilon}_o. \quad (16)$$

Stress-Strain Relation:

$$\boldsymbol{\sigma} = \mathbf{E}\boldsymbol{\varepsilon}_e = \mathbf{E}(\boldsymbol{\varepsilon} - \boldsymbol{\varepsilon}_o). \quad (17)$$

Thermal Stress Analysis Using the FEM:

- Need to specify α for the structure and ΔT on the related elements (which experience the temperature change).
- Note that for linear thermoelasticity, same temperature change will yield same stresses, even if the structure is at two different temperatures.
- Differences in the temperatures during the manufacturing and working environment are the main cause of thermal (residual) stresses.

Further Reading

1. O. C. Zienkiewicz and R. L. Taylor, [*The Finite Element Method*](#), 4th ed (McGraw-Hill, New York, 1989).
2. J. N. Reddy, [*An Introduction To The Finite Element Method*](#), Second Edition ed (McGraw-Hill, New York, 1993).
3. R. D. Cook, [*Finite Element Modeling For Stress Analysis*](#) (John Wiley & Sons, Inc., New York, 1995).
4. K. J. Bathe, [*Finite Element Procedures*](#) (Prentice Hall, Englewood Cliffs, NJ, 1996).
5. T. R. Chandrupatla and A. D. Belegundu, [*Introduction To Finite Elements in Engineering*](#), 3rd ed (Prentice Hall, Upper Saddle River, NJ, 2002).
6. R. D. Cook, D. S. Malkus, M. E. Plesha, and R. J. Witt, [*Concepts and Applications of Finite Element Analysis*](#), 4th ed (John Wiley & Sons, Inc., New York, 2002).
7. S. Moaveni, [*Finite Element Analysis - Theory and Application with ANSYS*](#), 2nd ed (Prentice-Hall, Upper Saddle River, NJ, 2002).